

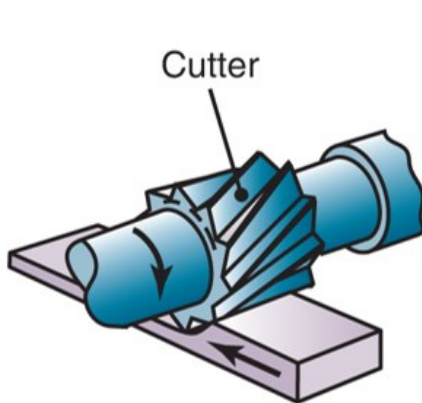

**THE UNIVERSITY OF ZAMBIA
SCHOOL OF ENGINEERING
MECHANICAL ENGINEERING
DEPARTMENT**

**MEC 3102 PRODUCTION ENGINEERING I
AND
ELECTRICITY & ELECTRONICS II**

MODULE 2: Lecture Notes



(c) Slab milling

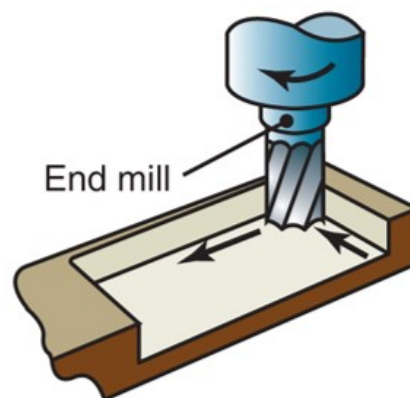

(d) End milling

MACHINING OPERATIONS AND MACHINE TOOLS

Upon completion of this module, you will be able to understand:

21.1 Machining and Part Geometry

21.2 Turning and Related Operations

- 21.2.1 Cutting Conditions in Turning
- 21.2.2 Operations Related to Turning
- 21.2.3 The Engine Lathe
- 21.2.4 Other Lathes and Turning Machines
- 21.2.5 Boring Machines

21.3 Drilling and Related Operations

- 21.3.1 Cutting Conditions in Drilling
- 21.3.2 Operations Related to Drilling
- 21.3.3 Drill Presses.

21.4 Milling

- 21.4.1 Types of Milling Operations
- 21.4.2 Cutting Conditions in Milling
- 21.4.3 Milling Machines

21.5 Machining Centers and Turning Centers

21.6 Other Machining Operations

- 21.6.1 Shaping and Planing
- 21.6.2 Broaching
- 21.6.3 Sawing

21.7 Machining Operations for Special Geometries

- 21.7.1 Screw Threads
- 21.7.2 Gears

21.8 High-Speed Machining

21. INTRODUCTION

Machining is the most versatile and accurate of all manufacturing processes in its capability to produce a diversity of part geometries and geometric features. Casting can also produce a variety of shapes, but it lacks the precision and accuracy of machining. This module/lecture describes the important machining operations and the machine tools used to perform them. Historical Note 21.1 provides a brief narrative of the development of machine tool technology.

21.1 MACHINING AND PART GEOMETRY

Machined parts can be classified as rotational or nonrotational (Figure 21.1). A **rotational** work part has a cylindrical or disk-like shape. The characteristic operation that produces this geometry is one in which a cutting tool removes material from a rotating work part. Examples include turning and boring. Drilling is closely related except that an internal cylindrical shape is created and the tool rotates (rather than the work) in most drilling operations. A **nonrotational (also called prismatic)** work part is block-like or plate-like, as in Figure 21.1(b). This geometry is achieved by linear motions of the work part, combined with either rotating or linear tool motions. Operations in this category include milling, shaping, planing, and sawing.

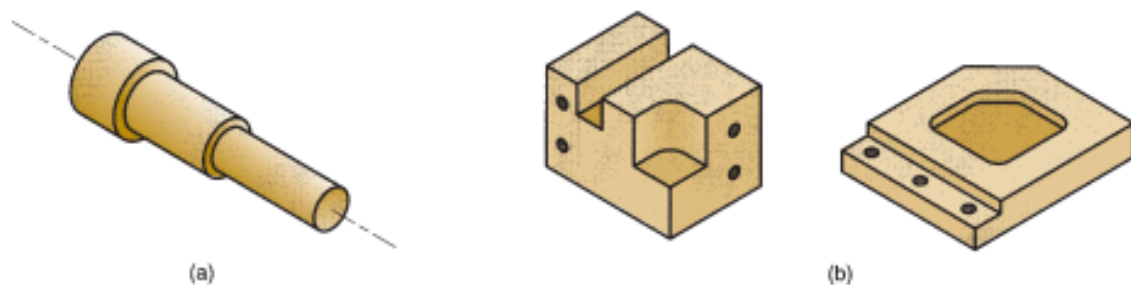

FIGURE 21.1 Machined parts are classified as (a) rotational, or (b) nonrotational, shown here by block and flat parts.

Historical Note 21.1 Machine tool technology

Material removal as a means of making things dates back to prehistoric times, when man learned to carve wood and chip stones to make hunting and farming implements. There is archaeological evidence that the ancient Egyptians used a rotating bowstring mechanism to drill holes.

Development of modern machine tools is closely related to the Industrial Revolution. When James Watt designed his steam engine in England around 1763, one of the technical problems he faced was to make the bore of the cylinder sufficiently accurate to prevent steam from escaping around the piston. John Wilkinson built a water-wheel powered boring machine around 1775, which permitted Watt to build his steam engine. This boring machine is often recognized as the first machine tool.

Another Englishman, Henry Maudsley, developed the first screw-cutting lathe around 1800. Although the turning of wood had been accomplished for many centuries, Maudsley's machine added a mechanized tool carriage with which feeding and threading operations could be performed with much greater precision than any means before. Eli Whitney is credited with developing the first milling machine in the United States around 1818. Development of the planer and shaper occurred in England between 1800 and 1835, in response to the need to make components for the steam engine, textile equipment, and other machines associated with the Industrial Revolution. The powered drill press was developed by James Nasmyth around 1846, which permitted drilling of accurate holes in metal.

Most of the conventional boring machines, lathes, milling machines, planers, shapers, and drill presses used today have the same basic designs as the early versions developed during the last two centuries. Modern machining centers—machine tools capable of performing more than one type of cutting operation—were introduced in the late 1950s, after numerical control had been developed (Historical Note 37.1).

Each machining operation produces a characteristic geometry due to two factors: (1) **the relative motions between the tool and the work part and** (2) **the shape of the cutting tool.** These operations that create part shape are classified as *generating* and *forming*. In generating, the geometry of the work part is determined by the feed trajectory of the cutting tool. The path followed by the tool during its feed motion is imparted to the work surface in order to create shape. Examples of generating include straight turning, taper turning, contour turning, peripheral milling, and profile milling, all illustrated in Figure 21.2. In each of these operations, material removal is accomplished by the speed motion in the operation, but part shape is determined by the feed motion. The feed trajectory may involve variations in depth or width of cut during the operation. For example, in the contour turning and profile milling operations shown in the figure, the feed motion results in changes in depth and width, respectively, as cutting proceeds.

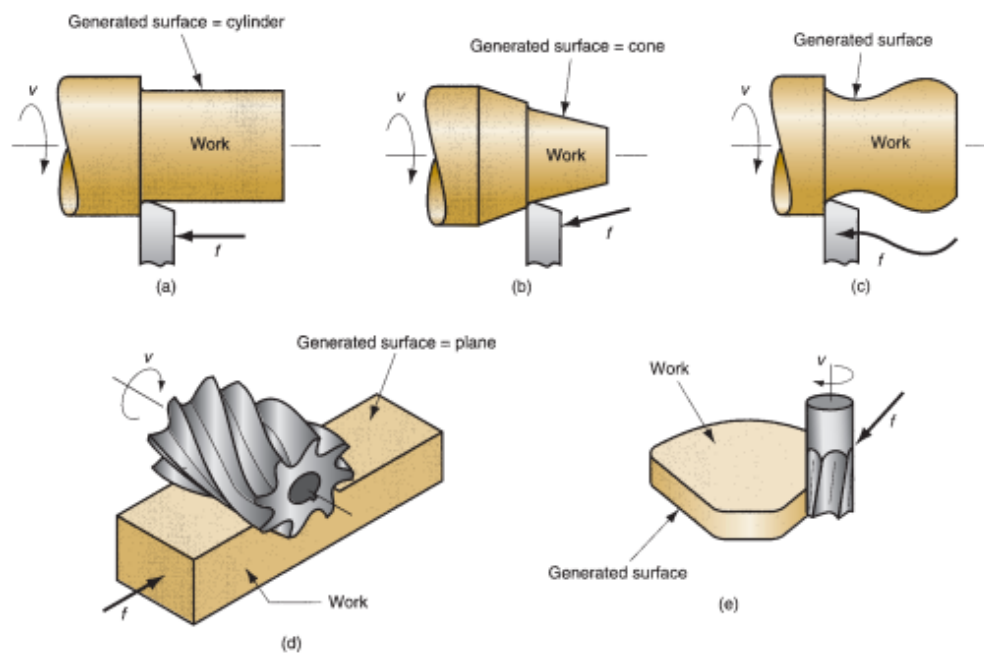

FIGURE 21.2 Generating shape in machining: (a) straight turning, (b) taper turning, (c) contour turning, (d) plain milling, and (e) profile milling.

In **forming**, the shape of the part is created by the geometry of the cutting tool. In effect, the cutting edge of the tool has the reverse of the shape to be

produced on the part surface. *Form turning, drilling, and broaching* are examples of this case. In these operations, illustrated in Figure 21.3, the shape of the cutting tool is imparted to the work in order to create part geometry. The cutting conditions in forming usually include the primary speed motion combined with a feeding motion that is directed into the work. Depth of cut in this category of machining usually refers to the final penetration into the work after the feed motion has been completed.

Forming and generating are sometimes combined in one operation, as illustrated in Figure 21.4 for thread cutting on a lathe and slotting on a milling machine. In thread cutting, the pointed shape of the cutting tool determines the form of the threads, but the large feed rate generates the threads. In slotting (also called slot milling), the width of the cutter determines the width of the slot, but the feed motion creates the slot.

Machining is classified as a secondary process. In general, secondary processes follow basic processes, whose purpose is to establish the initial shape of a workpiece. Examples of basic processes include casting, forging, and bar rolling (to produce rod and bar stock). The shapes produced by these processes usually require refinement by secondary processes. Machining operations serve to transform the starting shapes into the final geometries specified by the part designer. For example, bar stock is the initial shape, but the final geometry after a series of machining operations is a shaft.

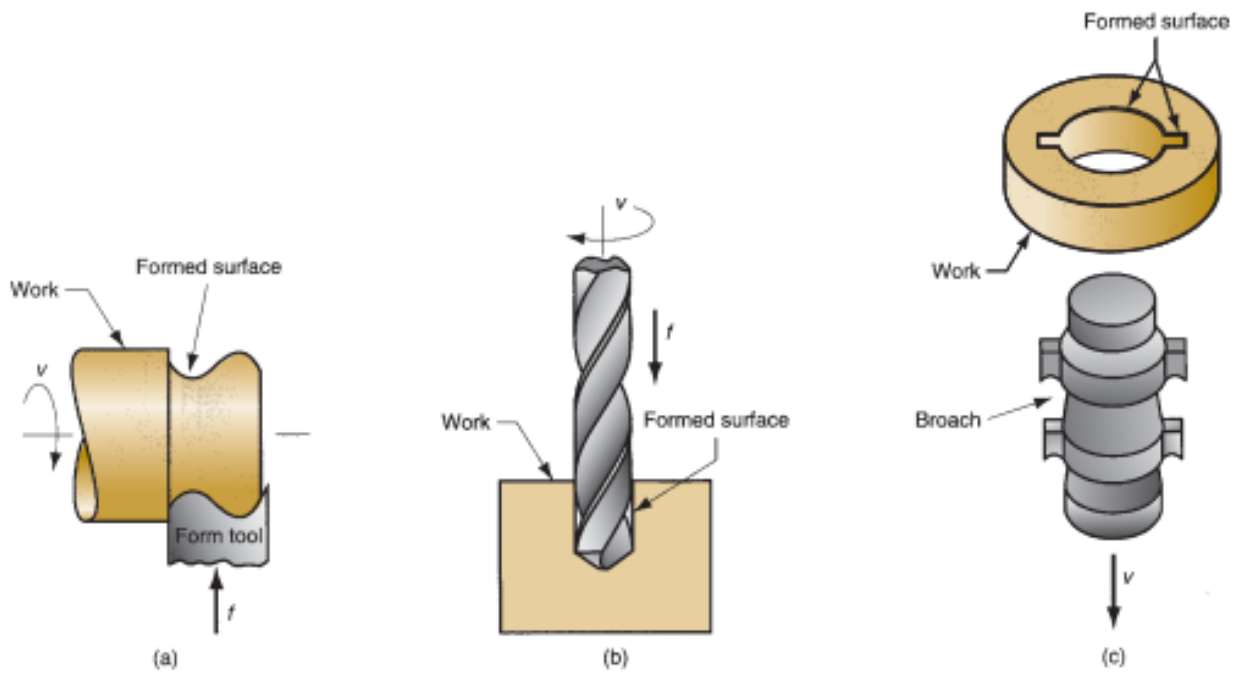

FIGURE 21.3 Forming to create shape in machining: (a) form turning, (b) drilling, and (c) broaching.

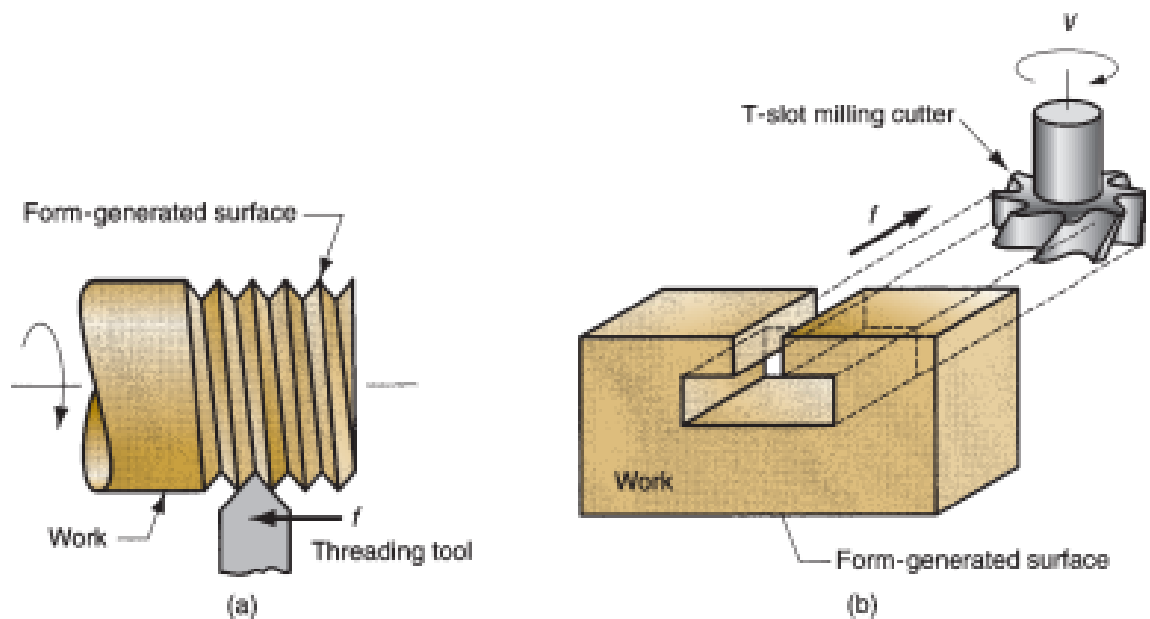

FIGURE 21.4 Combination of forming and generating to create shape: (a) thread cutting on a lathe, and (b) slot milling.

21.2 TURNING AND RELATED OPERATIONS

Turning is a machining process in which a single-point tool removes material from the surface of a rotating workpiece. The tool is fed linearly in a direction parallel to the axis of rotation to generate a cylindrical geometry, as illustrated in Figures 21.2(a) and 21.5. Turning is traditionally carried out on a machine tool called a lathe, which provides power to turn the part at a given rotational speed and to feed the tool at a specified rate and depth of cut.

21.2.1 CUTTING CONDITIONS IN TURNING

The rotational speed in turning is related to the desired cutting speed at the surface of the cylindrical workpiece by the equation.

$$N = \frac{v}{\pi D_0} \quad (21.1)$$

where N = rotational speed, rev/min; v = cutting speed, m/min (ft/min); and D_0 = original diameter of the part, m (ft).

The turning operation reduces the diameter of the work from its original diameter D_0 to a final diameter D_f , as determined by the depth of cut d :

$$D_f = D_0 - 2d \quad (21.2)$$

The feed in turning is generally expressed in mm/rev (in/rev). This feed can be converted to a linear travel rate in mm/min (in/min) by the formula

$$f_r = Nf \quad (21.3)$$

where f_r = feed rate, mm/min (in/min); and f = feed, mm/rev (in/rev)

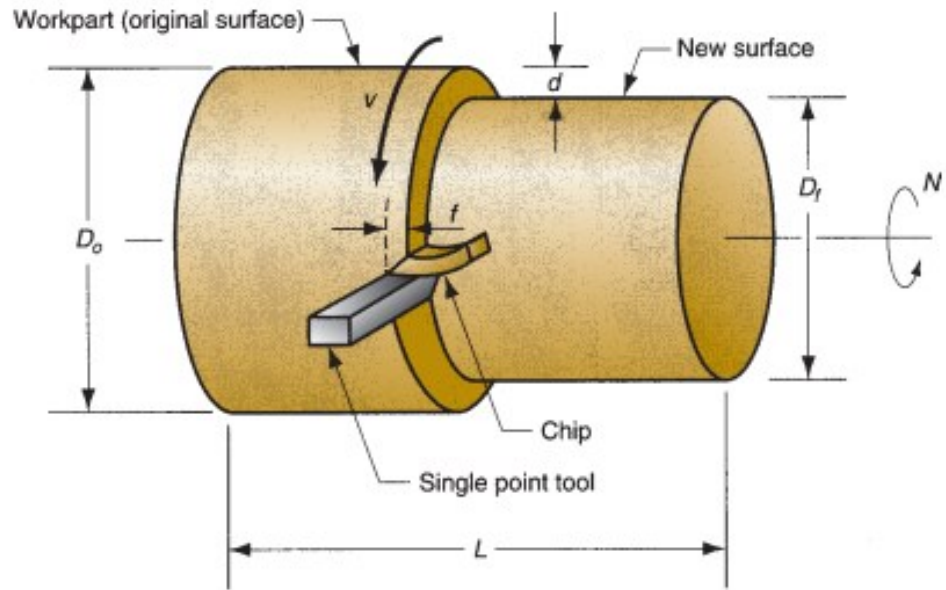

FIGURE 21.5 (a) Turning operation.

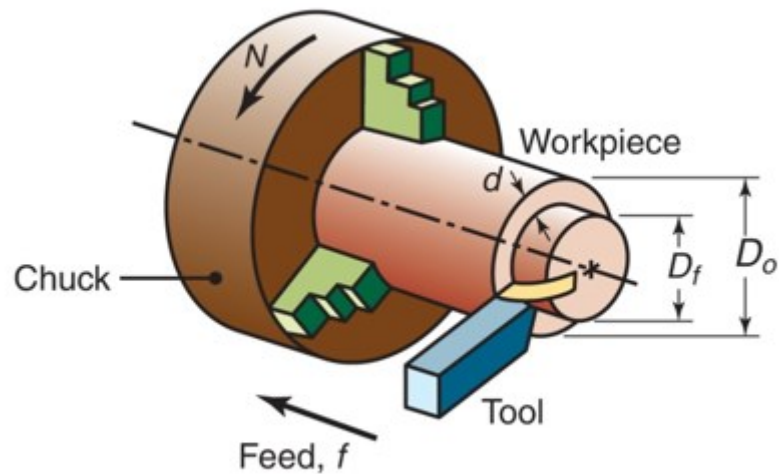

Figure 21.5 (b) Schematic illustration of the basic turning operation, showing depth of cut, d ; feed, f ; and spindle rotational speed, N , in rev/min. The cutting speed is the surface speed of the workpiece at the tool tip

The time to machine from one end of a cylindrical work part to the other is given by

$$T_m = \frac{L}{f_r} \quad (21.4)$$

where T_m = machining time, min; and L = length of the cylindrical work part, mm (in). A more direct computation of the machining time is provided by the following equation:

$$T_m = \frac{\pi D_0 L}{f_v} \quad (21.5)$$

where D_0 = work diameter, mm (in); L = work part length, mm (in); f = feed, mm/rev (in/rev); and v = cutting speed, mm/min (in/min). As a practical matter, a small distance is usually added to the work part length at the beginning and end of the piece to allow for approach and overtravel of the tool. Thus, the duration of the feed motion past the work will be longer than T_m . The volumetric rate of material removal can be most conveniently determined by the following equation:

$$R_{MR} = vfd \quad (21.6)$$

where R_{MR} = material removal rate, mm³ /min (in³/min). In using this equation, the units for f are expressed simply as mm (in), in effect neglecting the rotational character of turning. In addition, care must be exercised to ensure that the units for speed are consistent with those for f and d .

Example 21.1 Machining time in turning

A turning operation is performed on a cylindrical work part whose diameter = 120 mm and length = 450 mm. Cutting speed = 2.0 m/s, feed = 0.25 mm/rev, and depth of cut = 2.2 mm. Determine (a) cutting time and (b) material removal rate.

Solution: (a) For consistency of units, cutting speed $v = 2000$ mm/s. Using Equation (21.5),

$$T_m = \frac{\pi D_0 L}{f_v} = \frac{\pi (120)(450)}{(2000)(0.25)} = 339.3 \text{ s} = \mathbf{5.65 \text{ min}}$$

(b) $R_{MR} = 2000(0.25)(2.2) = \mathbf{1100 \text{ mm}^3/\text{s}}$

21.2.2 OPERATIONS RELATED TO TURNING

A variety of other machining operations can be performed on a lathe in addition to turning; these include the following, illustrated in Figure 21.6:

- (a) **Facing.** The tool is fed radially into the rotating work on one end to create a flat surface on the end.
- (b) **Taper turning.** Instead of feeding the tool parallel to the axis of rotation of the work, the tool is fed at an angle, thus creating a tapered cylinder or conical shape.
- (c) **Contour turning.** Instead of feeding the tool along a straight line parallel to the axis of rotation as in turning, the tool follows a contour that is other than straight, thus creating a contoured form in the turned part.
- (d) **Form turning.** In this operation, sometimes called forming, the tool has a shape that is imparted to the work by plunging the tool radially into the work.
- (e) **Chamfering.** The cutting edge of the tool is used to cut an angle on the corner of the cylinder, forming a “chamfer.”
- (f) **Cutoff.** The tool is fed radially into the rotating work at some location along its length to cut off the end of the part. This operation is sometimes referred to as parting.
- (g) **Threading.** A pointed tool is fed linearly across the outside surface of the rotating work part in a direction parallel to the axis of rotation at a large effective feed rate, thus creating threads in the cylinder.

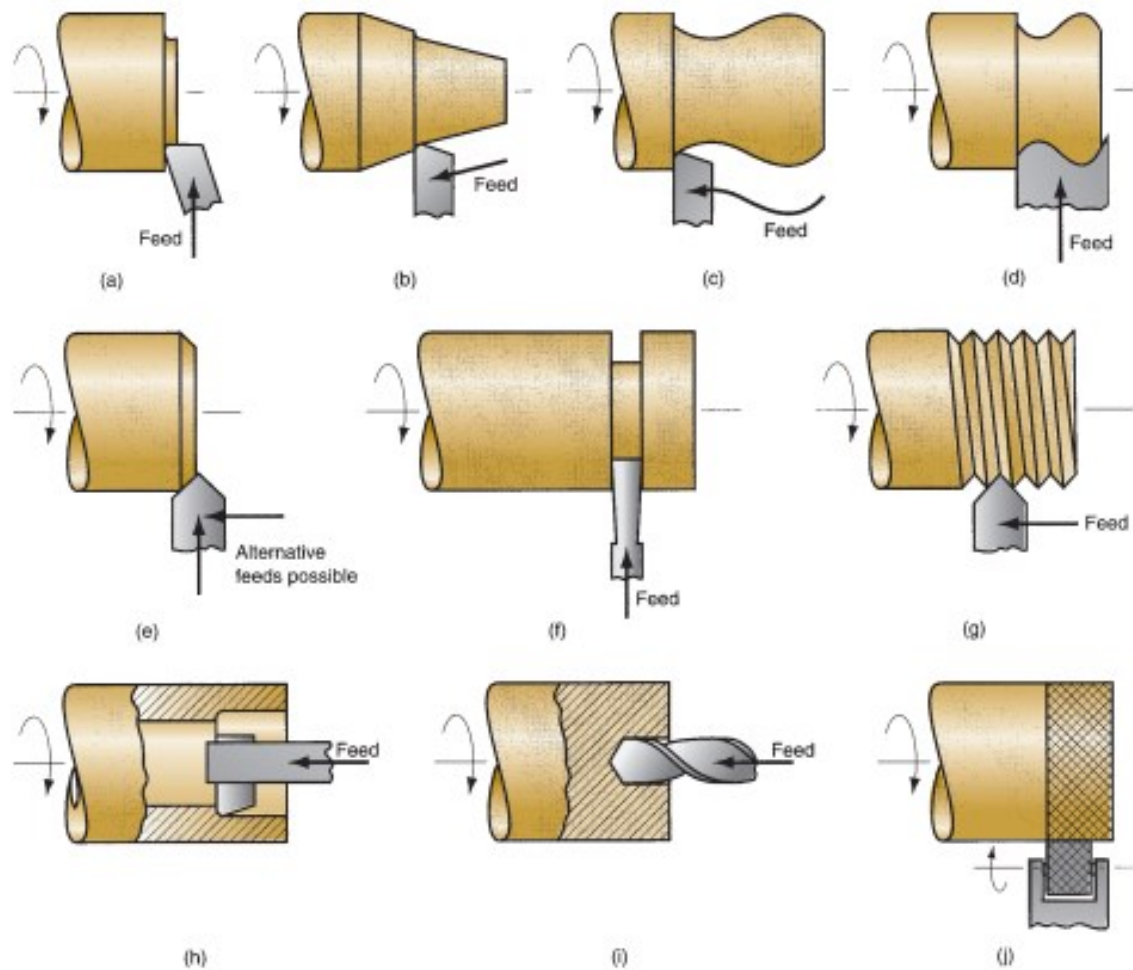

FIGURE 21.6 Machining operations other than turning that are performed on a lathe: (a) facing, (b) taper turning, (c) contour turning, (d) form turning, (e) chamfering, (f) cutoff, (g) threading, (h) boring, (i) drilling, and (j) knurling

(h) **Boring.** A single-point tool is fed linearly, parallel to the axis of rotation, on the inside diameter of an existing hole in the part.

(i) **Drilling.** Drilling can be performed on a lathe by feeding the drill into the rotating work along its axis. Reaming can be performed in a similar way.

(j) **Knurling.** This is not a machining operation because it does not involve cutting of material. Instead, it is a metal forming operation used to produce a regular cross-hatched pattern in the work surface.

Most lathe operations use single-point tools. Turning, facing, taper turning, contour turning, chamfering, and boring are all performed with single-point tools. A threading operation is accomplished using a single-point tool designed with a geometry that shapes the thread. Certain operations require tools other than single-point. Form turning is performed with a

specially designed tool called a form tool. The profile shape ground into the tool establishes the shape of the work part. A cut-off tool is basically a form tool. Drilling is accomplished by a drill bit. Knurling is performed by a knurling tool, consisting of two hardened forming rolls, each mounted between centers. The forming rolls have the desired knurling pattern on their surfaces. To perform knurling, the tool is pressed against the rotating work part with sufficient pressure to impress the pattern onto the work surface.

21.2.3 THE ENGINE LATHE

The basic lathe used for turning and related operations is an engine lathe. It is a versatile machine tool, manually operated, and widely used in low and medium production. The term engine dates from the time when these machines were driven by steam engines.

21.2.3.1 Engine Lathe Technology

Figure 21.7 is a sketch of an engine lathe showing its principal components. The headstock contains the drive unit to rotate the spindle, which rotates the work. Opposite the headstock is the tailstock, in which a center is mounted to support the other end of the workpiece.

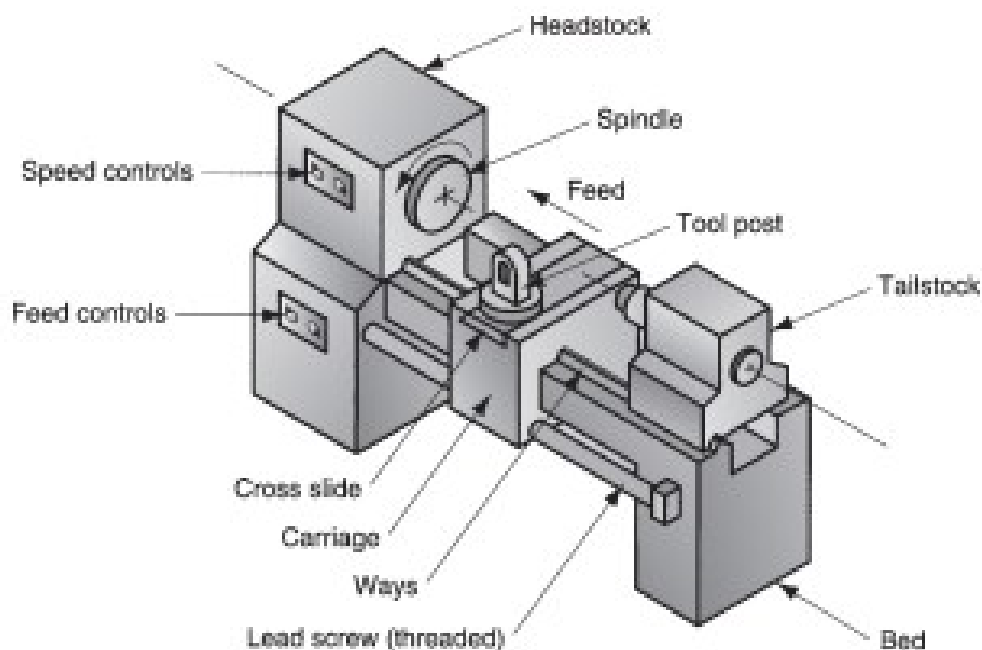

FIGURE 21.7 Diagram of an engine lathe, indicating its principal components.

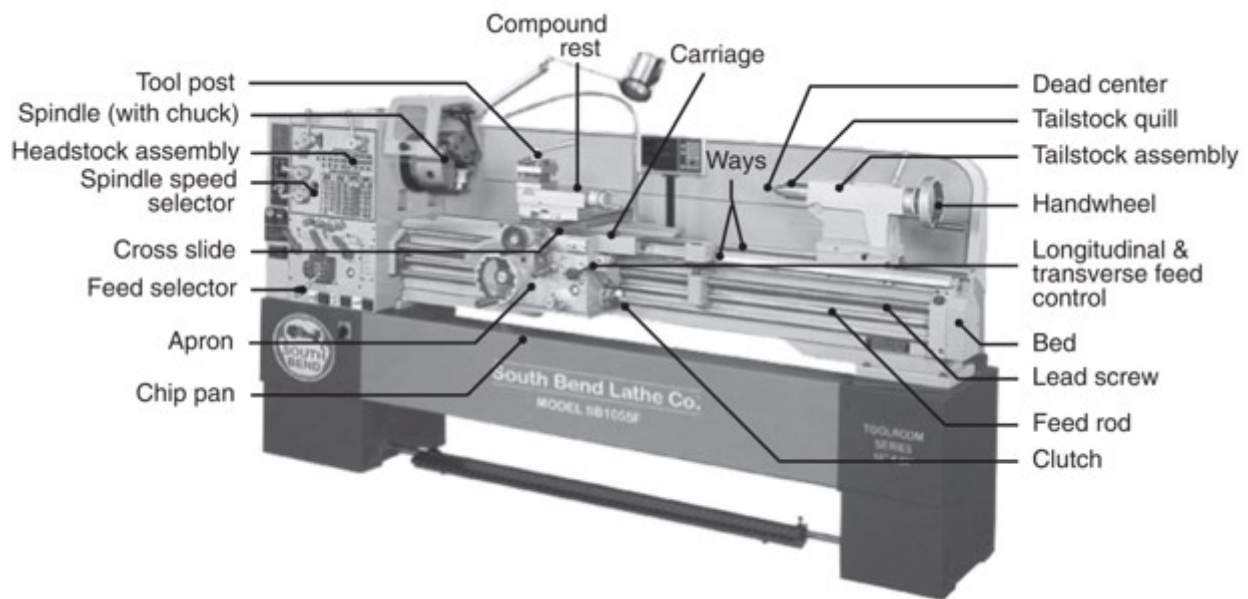

FIGURE 21.7 (b) General view of a typical lathe, showing various components.

The cutting tool is held in a tool post fastened to the **cross-slide**, which is assembled to the **carriage**. The carriage is designed to slide along the ways of the lathe in order to feed the tool parallel to the axis of rotation. The ways are like tracks along which the carriage rides, and they are made with great precision to achieve a high degree of parallelism relative to the spindle axis. The ways are built into the **bed** of the lathe, providing a rigid frame for the machine tool.

The carriage is driven by a leadscrew that rotates at the proper speed to obtain the desired feed rate. The cross-slide is designed to feed in a direction perpendicular to the carriage movement. Thus, by moving the carriage, the tool can be fed parallel to the work axis to perform straight turning; or by moving the cross-slide, the tool can be fed radially into the work to perform facing, form turning, or cutoff operations.

The conventional engine lathe and most other machines described in this section are **horizontal turning machines**; that is, the spindle axis is horizontal. This is appropriate for the majority of turning jobs, in which the length is greater than the diameter. For jobs in which the diameter is large

relative to length and the work is heavy, it is more convenient to orient the work so that it rotates about a vertical axis; these are vertical **turning machines**.

The size of a lathe is designated by swing and maximum distance between centers. The **swing** is the maximum work part diameter that can be rotated in the spindle, determined as twice the distance between the centerline of the spindle and the ways of the machine. The actual maximum size of a cylindrical workpiece that can be accommodated on the lathe is smaller than the swing because the carriage and cross-slide assembly are in the way. The **maximum distance between centers** indicates the maximum length of a workpiece that can be mounted between headstock and tailstock centers. For example, a 350 mm × 1.2 m (14 in × 48 in) lathe designates that the swing is 350 mm (14 in) and the maximum distance between centers is 1.2 m (48 in).

21.2.3.2 Methods of Holding the Work in a Lathe

There are four common methods used to hold work parts in turning. These work-holding methods consist of various mechanisms to grasp the work, center and support it in position along the spindle axis, and rotate it. The methods, illustrated in Figure 21.8, are (a) **mounting the work between centers**, (b) **chuck**, (c) **collet**, and (d) **face plate**.

Holding the work **between centers** refers to the use of two centers, one in the headstock and the other in the tailstock, as in Figure 21.8(a). This method is appropriate for parts with large length-to-diameter ratios. At the headstock center, a device called a **dog** is attached to the outside of the work and is used to drive the rotation from the spindle. The tailstock center has a cone-shaped point, which is inserted, into a tapered hole in the end of the work. The tailstock center is either a “live” center or a “dead” center. A **live center** rotates in a bearing in the tailstock, so that there is no relative rotation between the work and the live center, hence, no friction between the center and the workpiece. In contrast, a **dead center** is fixed to the tailstock, so that it does not rotate; instead, the workpiece rotates about it. Because of friction and the heat build-up that results, this setup is normally used at lower rotational speeds. The live center can be used at higher speeds.

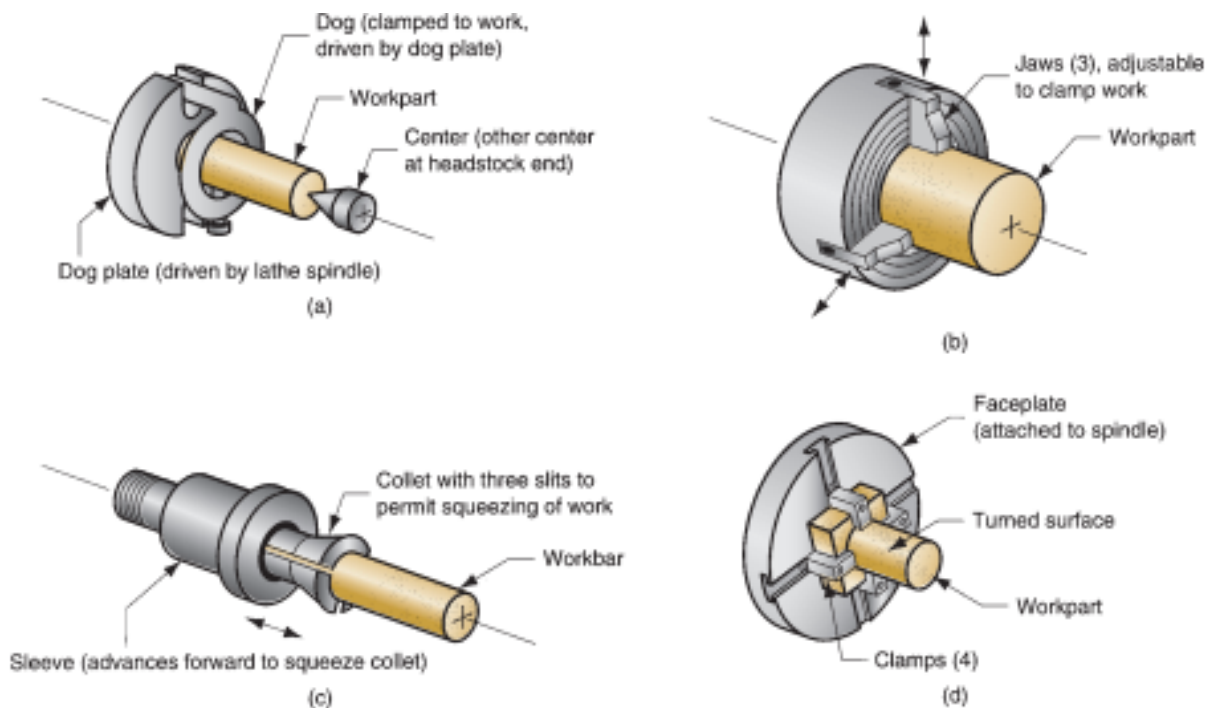
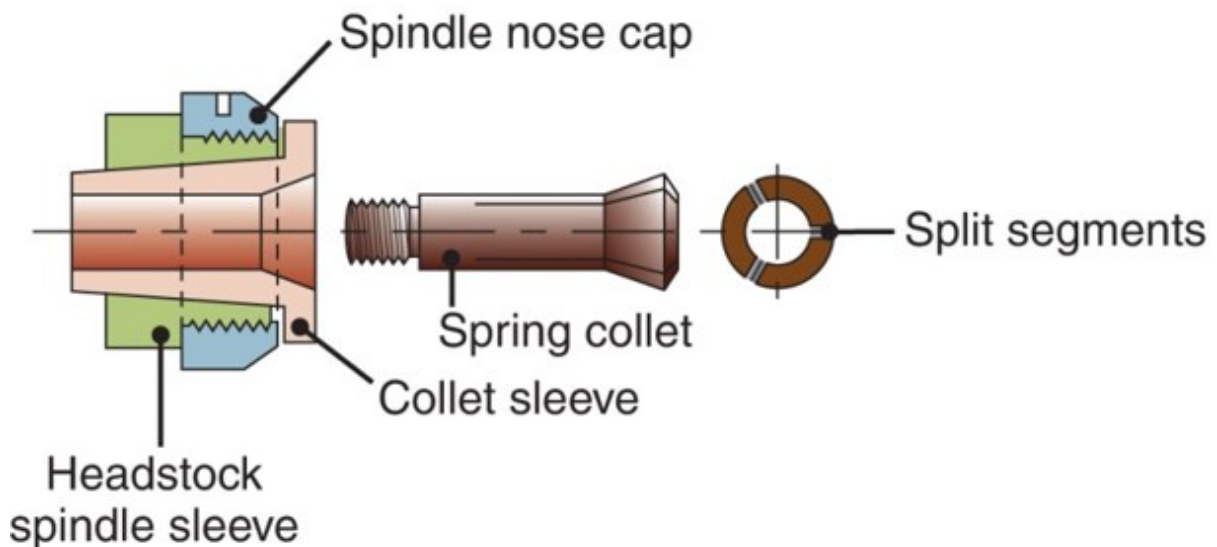

FIGURE 21.8 Four workholding methods used in lathes: (a) mounting the work between centers using a dog, (b) three-jaw chuck, (c) collet, and (d) faceplate for noncylindrical work parts.

The **chuck**, Figure 21.8(b), is available in several designs, with three or four jaws to grasp the cylindrical work part on its outside diameter. The jaws are often designed so they can also grasp the inside diameter of a tubular part. A **self-centering** chuck has a mechanism to move the jaws in or out simultaneously, thus centering the work at the spindle axis. Other chucks allow independent operation of each jaw. Chucks can be used with or without a tailstock center. For parts with low length-to-diameter ratios, holding the part in the chuck in a cantilever fashion is usually sufficient to withstand the cutting forces. For long workbars, the tailstock center is needed for support.

A **collet** consists of a tubular bushing with longitudinal slits running over half its length and equally spaced around its circumference, as in Figure 21.8(c). The inside diameter of the collet is used to hold cylindrical work such as barstock. Owing to the slits, one end of the collet can be squeezed to reduce its diameter and provide a secure grasping pressure against the work. Because there is a limit to the reduction obtainable in a collet of any given

diameter, these workholding devices must be made in various sizes to match the particular work part size in the operation.



(a) Schematic illustrations of a draw-in type of collet. The workpiece is placed in the collet hole, and the conical surfaces of the collet are forced inward by pulling it with a draw bar into the sleeve.

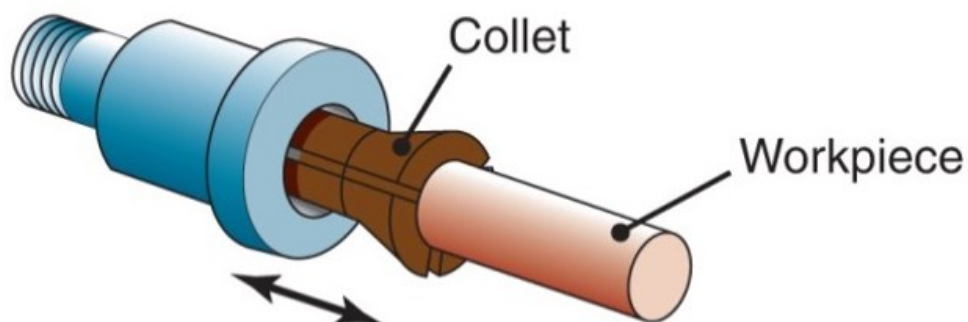

(b) Schematic illustrations of a draw-in type of collet. The workpiece is placed in the collet hole, and the conical surfaces of the collet are forced inward by pulling it with a draw bar into the sleeve.

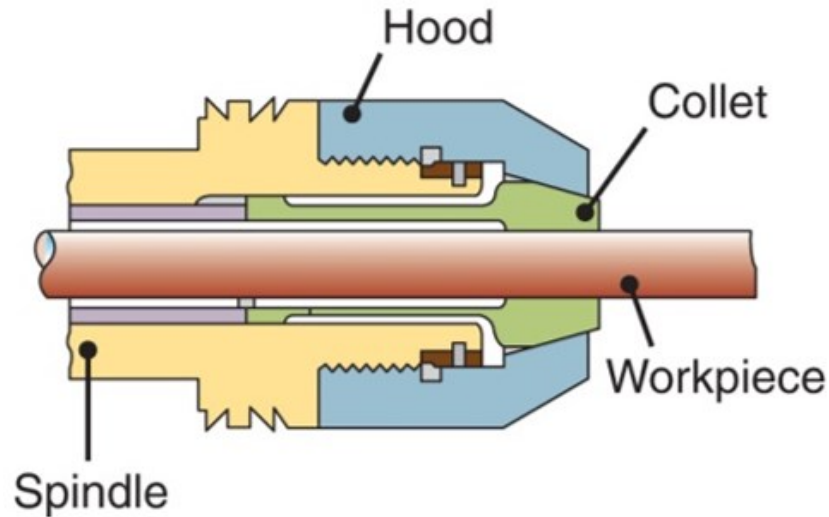

A push-out type of collet

A **faceplate**, Figure 21.8(d), is a work-holding device that fastens to the lathe spindle and is used to grasp parts with irregular shapes. Because of their irregular shape, these parts cannot be held by other work holding methods. The faceplate is therefore equipped with the custom-designed clamps for the particular geometry of the part.

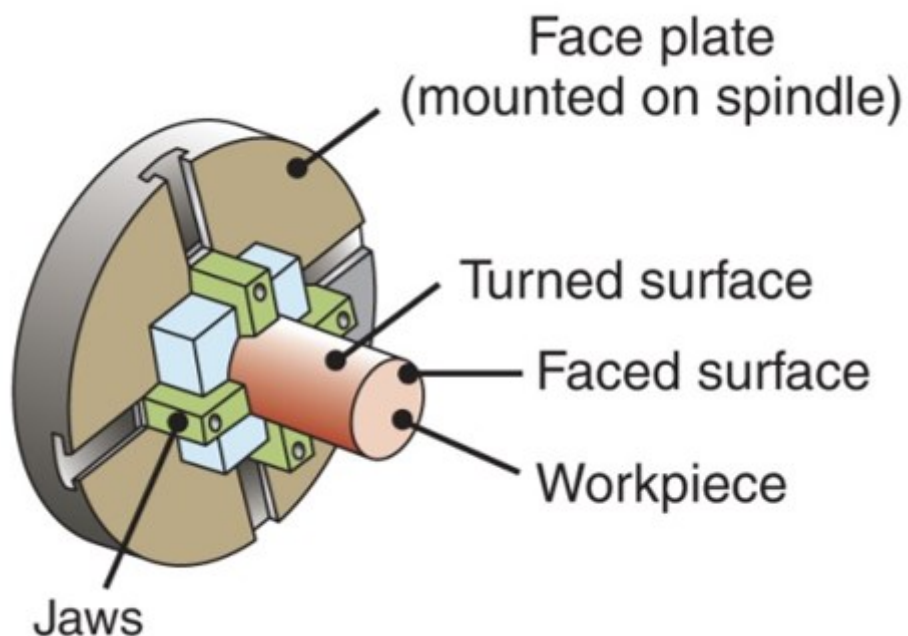

(d) Workholding of a workpiece on a faceplate.

21.2.4 OTHER LATHES AND TURNING MACHINES

In addition to the engine lathe, other turning machines have been developed to satisfy particular functions or to automate the turning process. Among these machines are (1) tool room lathe, (2) speed lathe, (3) turret lathe, (4) chucking machine, (5) automatic screw machine, and (6) numerically controlled lathe.

The tool room lathe and speed lathe are closely related to the engine lathe. The **tool room lathe** is smaller and has a wider available range of speeds and feeds. It is also built for higher accuracy, consistent with its purpose of fabricating components for tools, fixtures, and other high-precision devices. The **speed lathe** is simpler in construction than the engine lathe. It has no carriage and cross-slide assembly, and therefore no leadscrew to drive the carriage. The cutting tool is held by the operator using a rest attached to the lathe for support. The speeds are higher on a speed lathe, but the number of speed settings is limited. Applications of this machine type include wood turning, metal spinning, and polishing operations.

A **turret lathe** is a manually operated lathe in which the tailstock is replaced by a turret that holds up to six cutting tools. These tools can be rapidly brought into action against the work one by one by indexing the turret. In addition, the conventional tool post used on an engine lathe is replaced by a four-sided turret that is capable of indexing up to four tools into position. Hence, because of the capacity to quickly change from one cutting tool to the next, the turret lathe is used for high-production work that requires a sequence of cuts to be made on the part.

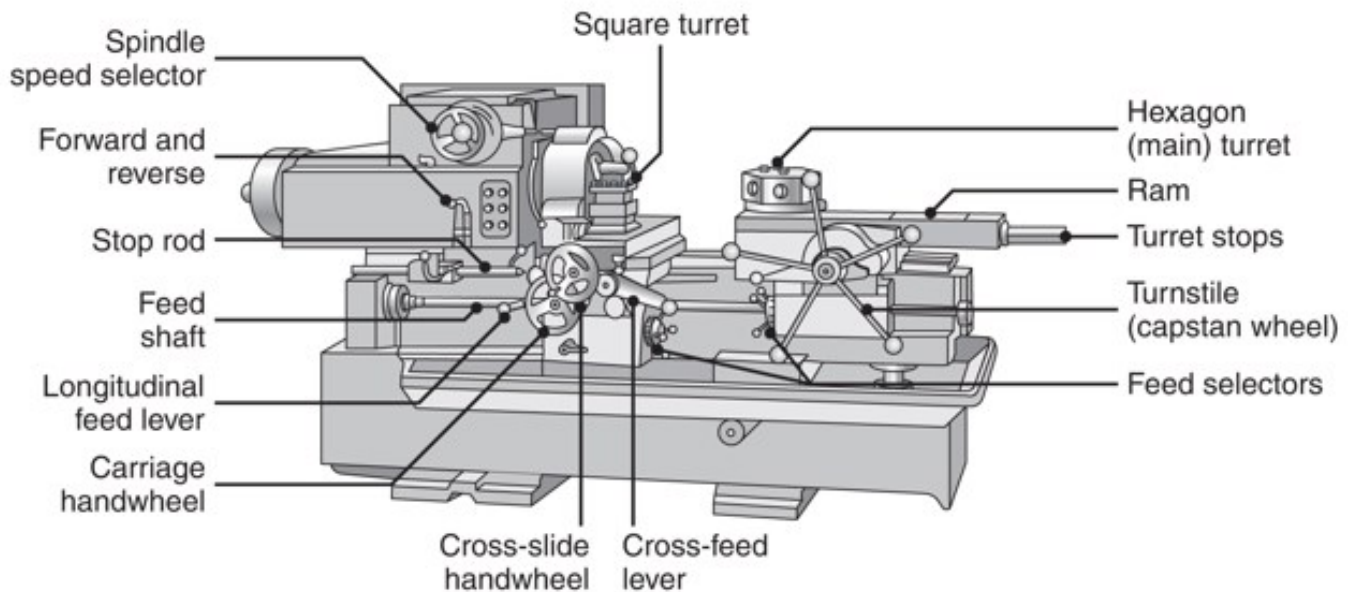

Schematic illustration of the components of a turret lathe; note the two turrets: square and hexagonal (main).

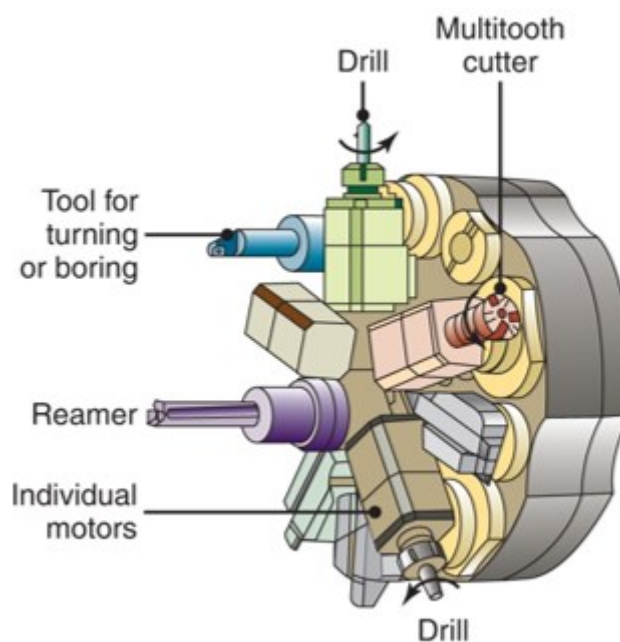

A typical turret equipped with 10 tools, some of which are powered.

As the name suggests, a **chucking machine** (nicknamed **chucker**) uses a chuck in its spindle to hold the work part. The tailstock is absent on a chucker, so parts cannot be mounted between centers. This restricts the use of a chucking machine to short, light-weight parts. The setup and operation

are similar to a turret lathe except that the feeding actions of the cutting tools are controlled automatically rather than by a human operator. The function of the operator is to load and unload the parts.

A **bar machine** is similar to a chucking machine except that a collet is used (instead of a chuck), which permits long bar stock to be fed through the headstock into position. At the end of each machining cycle, a cutoff operation separates the new part. The bar stock is then indexed forward to present stock for the next part. Feeding the stock as well as indexing and feeding the cutting tools is accomplished automatically. Owing to its high level of automatic operation, it is often called an **automatic bar machine**. One of its important applications is in the production of screws and similar small hardware items; the name **automatic screw machine** is frequently used for machines used in these applications.

Bar machines can be classified as single spindle or multiple spindle. A **single spindle bar machine** has one spindle that normally allows only one cutting tool to be used at a time on the single work part being machined. Thus, while each tool is cutting the work, the other tools are idle. (Turret lathes and chucking machines are also limited by this sequential, rather than simultaneous, tool operation). To increase cutting tool utilization and production rate, **multiple spindle bar machines** are available. These machines have more than one spindle, so multiple parts are machined simultaneously by multiple tools. For example, a six-spindle automatic bar machine works on six parts at a time, as in Figure 21.9. At the end of each machining cycle, the spindles (including collets and workbars) are indexed (rotated) to the next position. In the illustration, each part is cut sequentially by five sets of cutting tools, which takes six cycles (position 1 is for advancing the bar stock to a “stop”). With this arrangement, a part is completed at the end of each cycle. As a result, a six-spindle automatic screw machine has a very high production rate. The sequencing and actuation of the motions on screw machines and chucking machines have traditionally been controlled by cams and other mechanical devices.

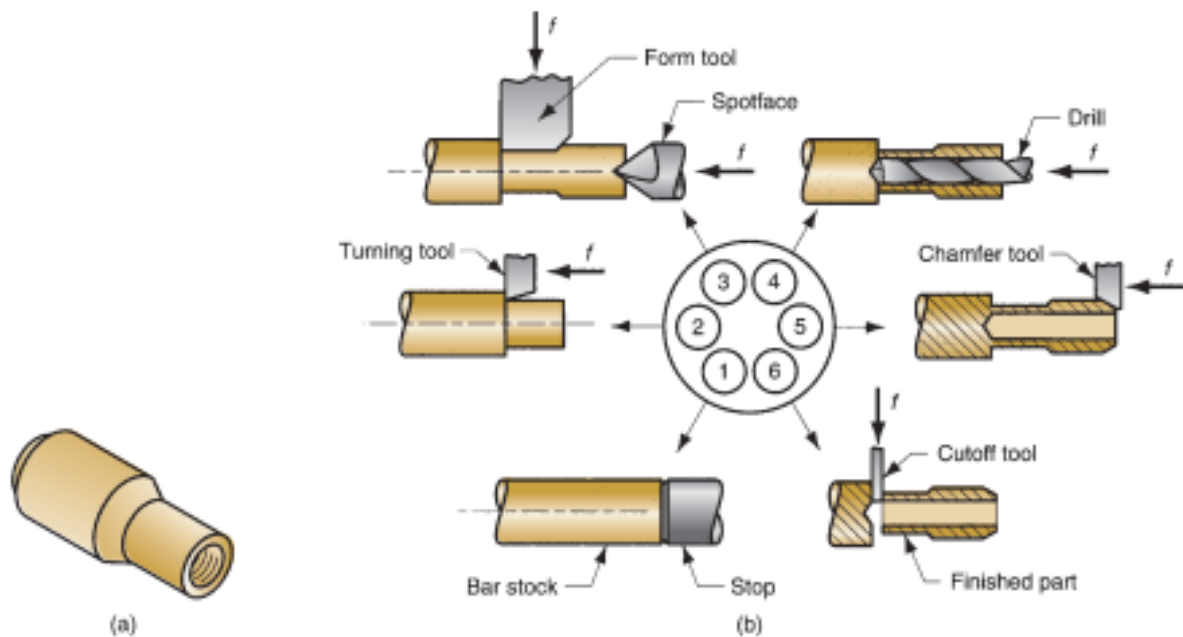
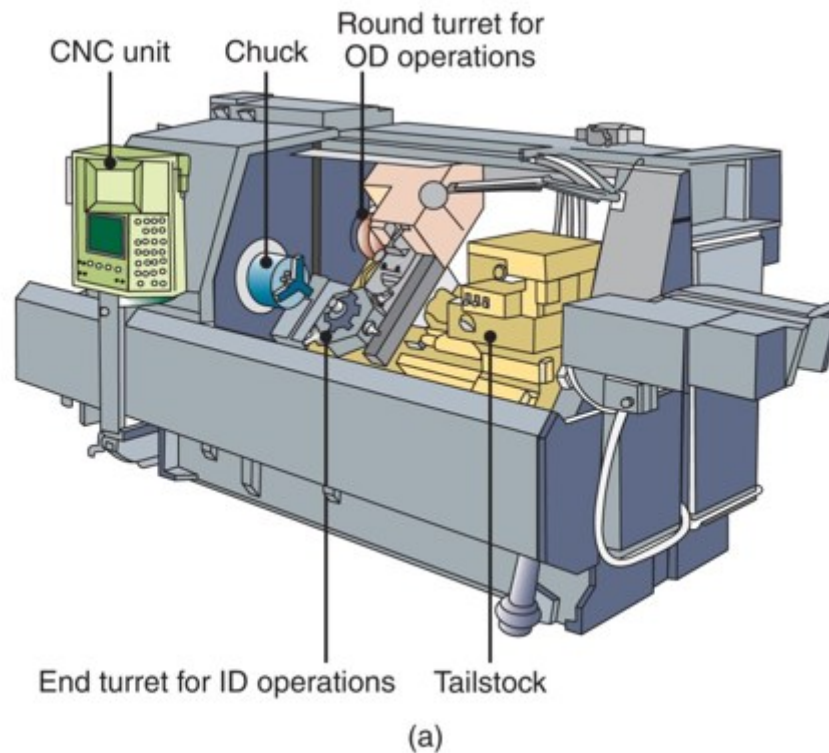

FIGURE 21.9 (a) Type of part produced on a six-spindle automatic bar machine; and (b) sequence of operations to produce the part: (1) feed stock to stop, (2) turn main diameter, (3) form second diameter and spotface, (4) drill, (5) chamfer, and (6) cutoff.

The modern form of control is **computer numerical control** (CNC), in which the machine tool operations are controlled by a “program of instructions” consisting of alphanumeric code. CNC provides a more sophisticated and versatile means of control than mechanical devices. CNC has led to the development of machine tools capable of more complex machining cycles and part geometries, and a higher level of automated operation than conventional screw machines and chucking machines. The CNC lathe is an example of these machines in turning. It is especially useful for contour turning operations and close tolerance work. Today, automatic chuckers and bar machines are implemented by CNC.



(a) A computer-numerical-control lathe with two turrets

21.2.5 BORING MACHINES

Boring is similar to turning. It uses a single-point tool against a rotating work part. The difference is that boring is performed on the inside diameter of an existing hole rather than the outside diameter of an existing cylinder. In effect, boring is an internal turning operation. Machine tools used to perform boring operations are called **boring machines** (also **boring mills**). One might expect that boring machines would have features in common with turning machines; indeed, as previously indicated, lathes are sometimes used to accomplish boring. Boring mills can be horizontal or vertical. The designation refers to the orientation of the axis of rotation of the machine spindle or work part. In a **horizontal boring** operation, the setup can be arranged in either of two ways. The first setup is one in which the work is fixtured to a rotating spindle, and the tool is attached to a cantilevered boring bar that feeds into the work, as illustrated in Figure 21.10(a).

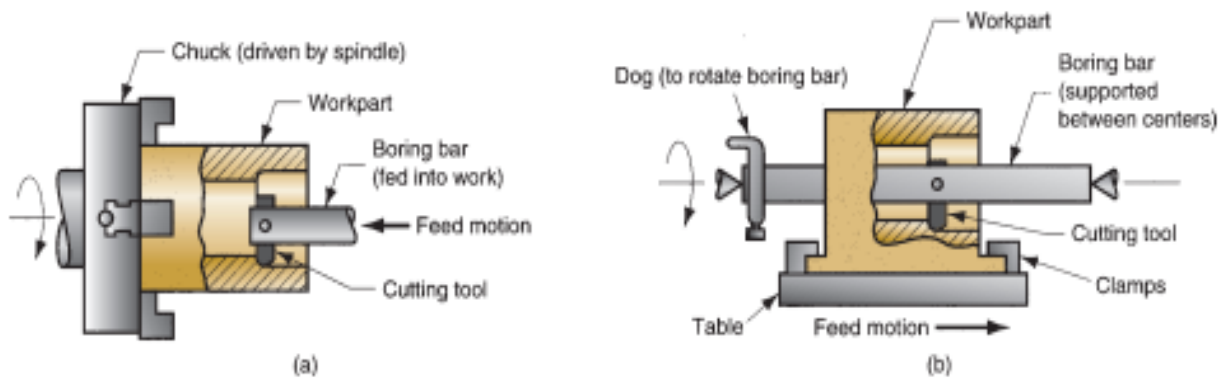

FIGURE 21.10 Two forms of horizontal boring: (a) boring bar is fed into a rotating work part, and (b) work is fed past a rotating boring bar.

The boring bar in this setup must be very stiff to avoid deflection and vibration during cutting. To achieve high stiffness, boring bars are often made of cemented carbide, whose modulus of elasticity approaches 620×10^3 MPa (90×10^6 lb/in²). Figure 21.11 shows a carbide-boring bar.

The second possible setup is one in which the tool is mounted to a boring bar, and the boring bar is supported and rotated between centers. The work is fastened to a feeding mechanism that feeds it past the tool. This setup, Figure 21.10(b), can be used to perform a boring operation on a conventional engine lathe.



FIGURE 21.11 Boring bar made of cemented carbide (WC-Co) that uses indexable cemented carbide inserts. (Courtesy of Kennametal Inc.)

A **vertical boring machine** is used for large, heavy work parts with large diameters; usually the work part diameter is greater than its length. As in Figure 21.12, the part is clamped to a worktable that rotates relative to the machine base. Worktables up to 40 ft in diameter are available. The typical boring machine can position and feed several cutting tools simultaneously. The tools are mounted on tool heads that can be fed horizontally and vertically relative to the worktable. One or two heads are mounted on a horizontal cross-rail assembled to the machine tool housing above the worktable. The cutting tools mounted above the work can be used for facing and boring. In addition to the tools on the cross-rail, one or two additional tool heads can be mounted on the side columns of the housing to enable turning on the outside diameter of the work.

The tool heads used on a vertical boring machine often include turrets to accommodate several cutting tools. This results in a loss of distinction between this machine and a **vertical turret lathe**. Some machine tool builders make the distinction that the vertical turret lathe is used for work diameters up to 2.5 m (100 in), while the vertical boring mill is used for larger diameters [7]. In addition, vertical boring mills are often applied to one-of-a-kind jobs, while vertical turret lathes are used for batch production.

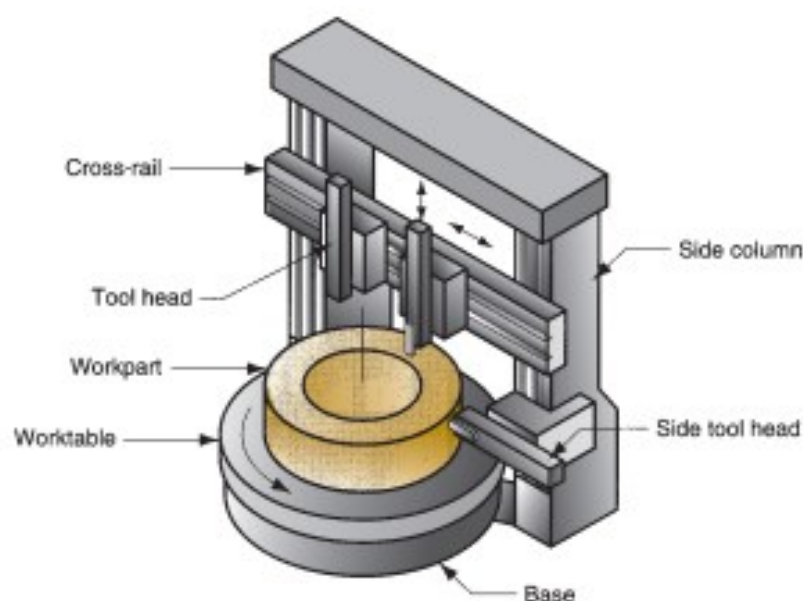

FIGURE 21.12: A vertical boring mill.

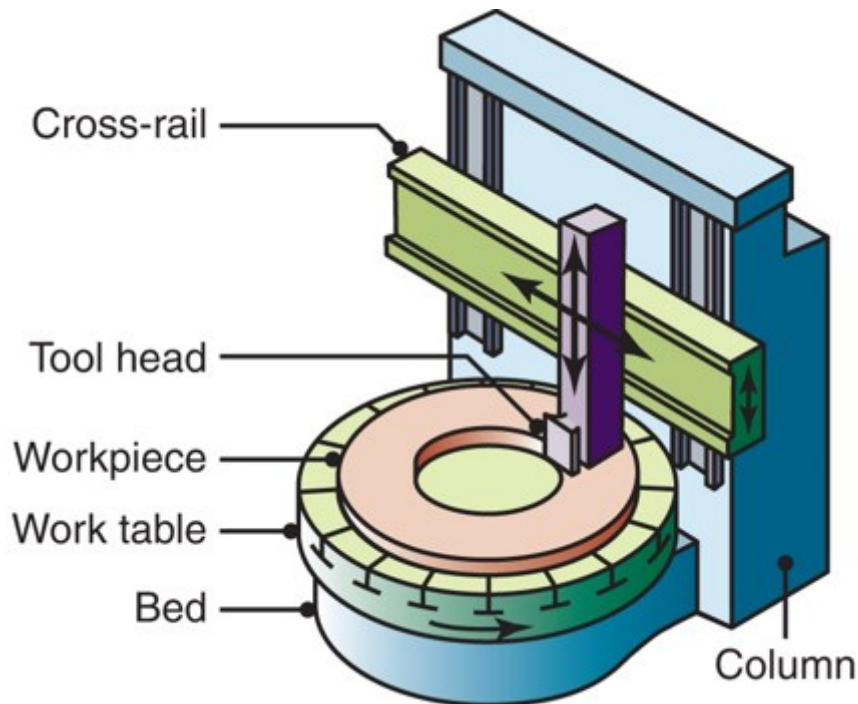

FIGURE 21.12: Schematic illustration of a **vertical boring mill**. Such a machine can accommodate workpiece sizes as large as 2.5 m (98 in.) in diameter.

21.3 DRILLING AND RELATED OPERATIONS

Drilling, Figure 21.3(b) is a machining operation used to create a round hole in a work part. This contrast with boring, which can only be used to enlarge an existing hole. Most drilling operations are performed using a rotating cylindrical tool that has two cutting edges on its working end. The tool is called a **drill** or **drill bit**, the most common form of which is the twist drill. The rotating drill feeds into the stationary work part to form a hole whose diameter is equal to the drill diameter. Drilling is customarily performed on a **drill press**, although other machine tools also perform this operation.

21.3.1 CUTTING CONDITIONS IN DRILLING

The cutting speed in a drilling operation is the surface speed at the outside diameter of the drill. It is specified in this way for convenience, even though

nearly all of the cutting is actually performed at lower speeds closer to the axis of rotation. To set the desired cutting speed in drilling, it is necessary to determine the rotational speed of the drill. Letting N represent the spindle rev/min,

$$N = \frac{v}{\pi D} \quad (21.7)$$

where v = cutting speed, mm/min (in/min); and D = the drill diameter, mm (in). In some drilling operations, the workpiece is rotated about a stationary tool, but the same formula applies.

Feed f in drilling is specified in mm/rev (in/rev). Recommended feeds are roughly proportional to drill diameter; higher feeds are used with larger diameter drills. Since there are (usually) two cutting edges at the drill point, the uncut chip thickness (chip load) taken by each cutting edge is half the feed. Feed can be converted to feed rate using the same equation as for turning:

$$f_r = Nf \quad (21.8)$$

where f_r = feed rate, mm/min (in/min).

Drilled holes are either through holes or through blind holes, shown in Figure 21.13 with a twist drill at the beginning of the operation. In through holes, the drill exits the opposite side of the work; in blind holes, it does not. The machining time required to drill a through hole can be determined by the following formula:

$$T_m = \frac{t+A}{f_r} \quad (21.9)$$

where T_m = machining (drilling) time, min; t = work thickness, mm (in); f_r = feed rate, mm/min (in/min); and A = an approach allowance that accounts for the drill point angle, representing the distance the drill must feed into the work before reaching full diameter, Figure 21.13(a). This allowance is given by

$$A = 0.5 D \tan\left(90 - \frac{\theta}{2}\right) \quad (21.10)$$

where A = approach allowance, mm (in); and θ = drill point angle, °. In drilling a through hole, the feed motion usually proceeds slightly beyond the opposite

side of the work, thus making the actual duration of the cut greater than T_m in Equation (21.9) by a small amount.

In a blind-hole, hole depth d is defined as the distance from the work surface to the depth of the full diameter, Figure 21.13(b). Thus, for a blind hole, machining time is given by

$$T_m = \frac{d+A}{f_r} \quad (21.11)$$

where A = the approach allowance by Equation (21.10).

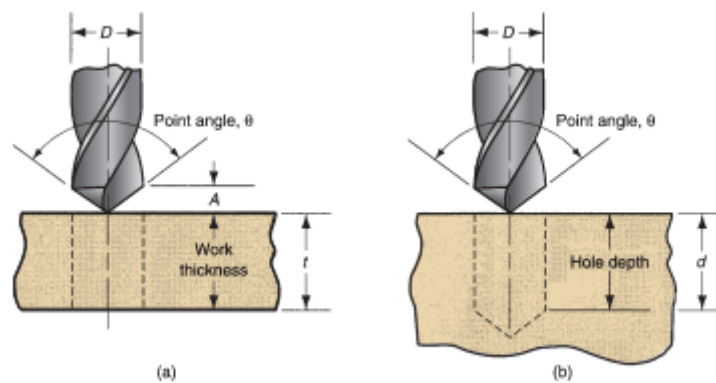

FIGURE 21.13 Two hole types: (a) through hole and (b) blind hole.

The rate of metal removal in drilling is determined as the product of the drill cross-sectional area and the feed rate:

$$R_{MR} = \frac{\pi D^2 f_r}{4} \quad (21.12)$$

This equation is valid only after the drill reaches full diameter and excludes the initial approach of the drill into the work.

Example 21.2 Machining time in drilling

A drilling operation is performed to create a through hole on a steel plate that is 15 mm thick. Cutting speed = 0.5 m/s, and feed = 0.22 mm/rev. The 20-

mm diameter twist drill has a point angle of 118° . Determine (a) the machining time and (b) metal removal rate once the drill reaches full diameter.

Solution:

$$(a) N = v/\pi D = 0.5(10^3)/\pi(20) = 7.96 \text{ rev/s}$$

$$f_r = Nf = 7.96(0.22) = 1.75 \text{ mm/s}$$

$$A = 0.5(20)\tan\left(90 - \frac{118}{2}\right) = 6.01 \text{ mm}$$

$$T_m = (t + A)/f_r = (15 + 6.01)/1.75 = 12.0 \text{ s} = \mathbf{0.20 \text{ min}}$$

$$(b) R_{MR} = \pi(20)^2(1.75)/4 = \mathbf{549.8 \text{ mm}^3/\text{s}}$$

21.3.2 OPERATIONS RELATED TO DRILLING

Several operations related to drilling are illustrated in Figure 21.14 and described in this section. Most of the operations follow drilling; a hole must be made first by drilling, and then the hole is modified by one of the other operations. Centering and spot facing are exceptions to this rule. All of the operations use rotating tools.

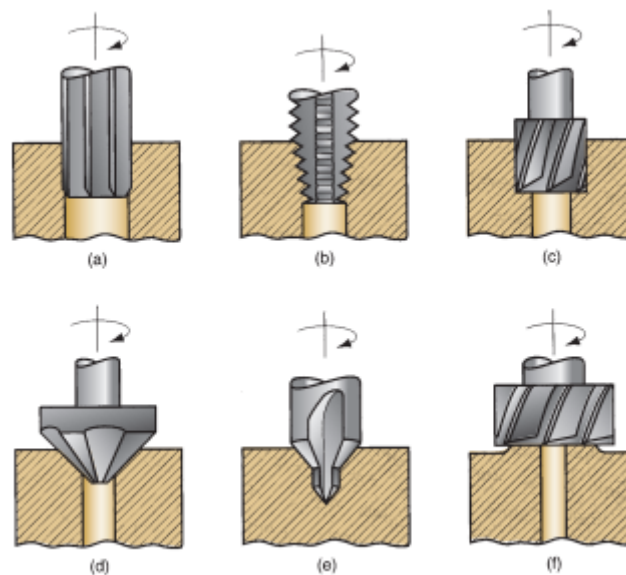

FIGURE 21.14(a) Machining operations related to drilling: (a) reaming, (b) tapping, (c) counterboring, (d) countersinking, (e) center drilling, and (f) spot facing.

- (a) **Reaming.** Reaming is used to slightly enlarge a hole, to provide a better tolerance on its diameter, and to improve its surface finish. The tool is called a reamer, and it usually has straight flutes.
- (b) **Tapping.** This operation is performed by a tap and is used to provide internal screw threads on an existing hole.
- (c) **Counterboring.** Counterboring provides a stepped hole, in which a larger diameter follows a smaller diameter partially into the hole. A counterbored hole is used to seat a bolt head into a hole so the head does not protrude above the surface.
- (d) **Countersinking.** This is similar to counterboring, except that the step in the hole is cone-shaped for flat head screws and bolts.
- (e) **Centering.** Also called center drilling, this operation drills a starting hole to accurately establish its location for subsequent drilling. The tool is called a center drill.
- (f) **Spot facing.** Spot facing is similar to milling. It is used to provide a flat machined surface on the work part in a localized area.

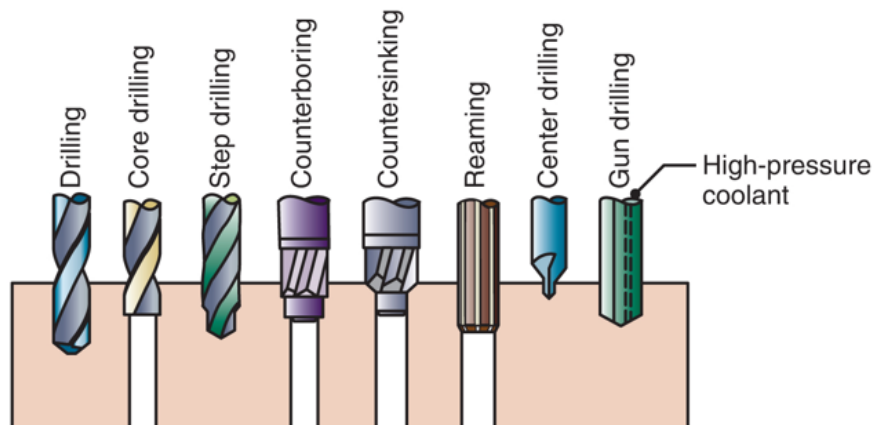

FIGURE 21.14(b): Various types of drills and drilling and reaming operations.

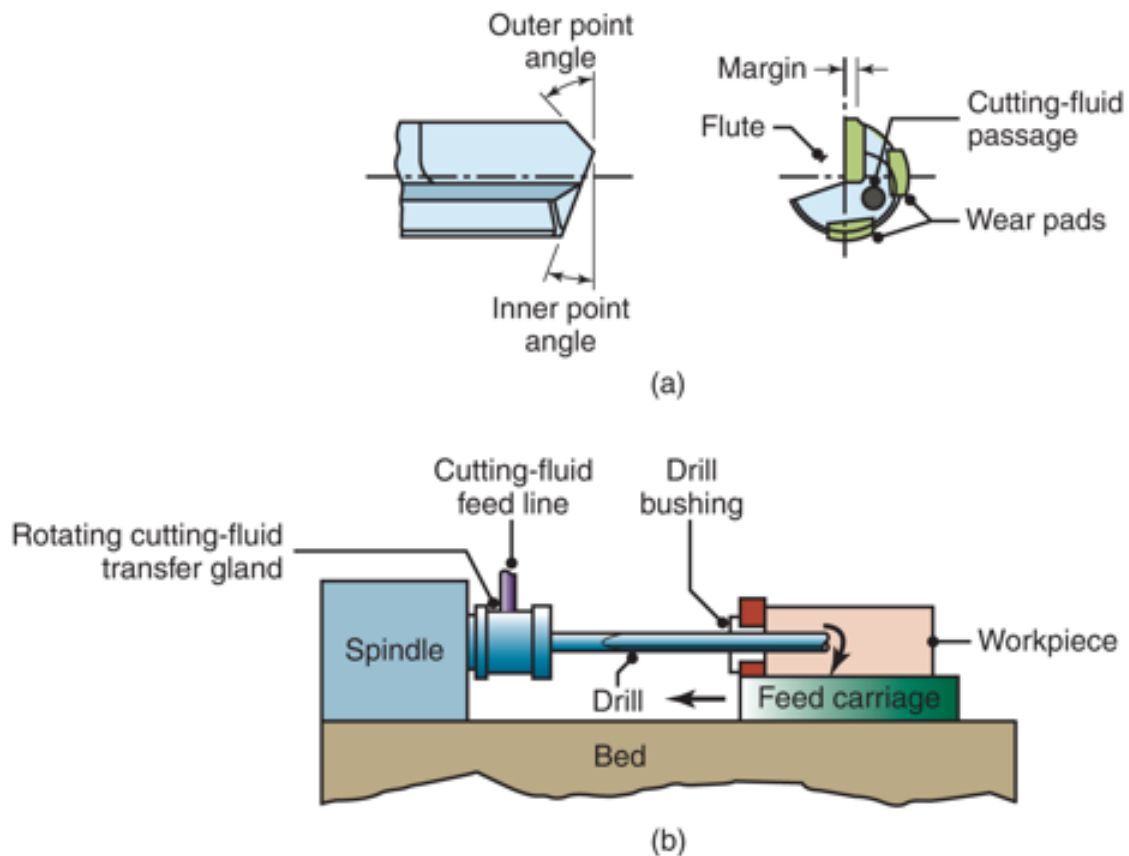

FIGURE 21.14 (a) A gun drill, showing various features. (b) Schematic illustration of the gun-drilling operation.

21.3.3 DRILL PRESSES

The standard machine tool for drilling is the drill press. There are various types of drill press, the most basic of which is the upright drill, Figure 21.15. The upright drill stands on the floor and consists of a table for holding the work part, a drilling head with powered spindle for the drill bit, and a base and column for support. A similar drill press, but smaller, is the **bench drill**, which is mounted on a table or bench rather than the floor.

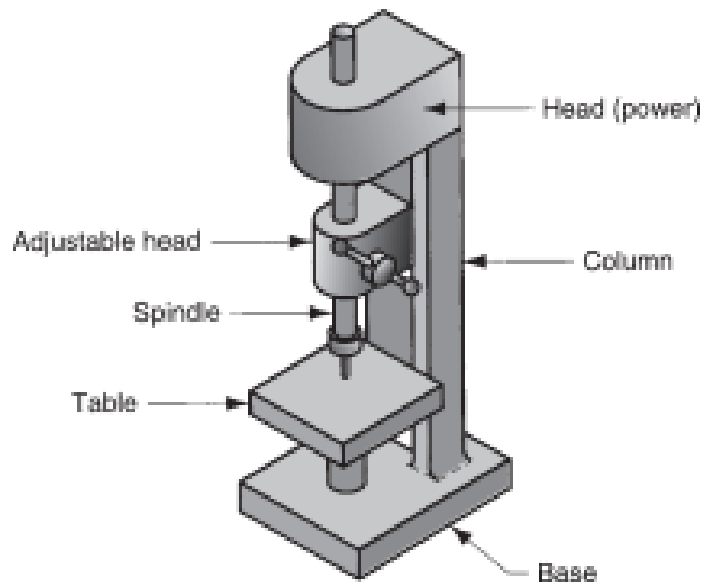

FIGURE 21.15 Upright drill press.

The **radial drill**, Figure 21.16, is a large drill press designed to cut holes in large parts. It has a radial arm along which the drilling head can be moved and clamped. The head therefore can be positioned along the arm at locations that are a significant distance from the column to accommodate large work. The radial arm can also be swiveled about the column to drill parts on either side of the worktable.

The **gang drill** is a drill press consisting basically of two to six upright drills connected together in an in-line arrangement. Each spindle is powered and operated independently, and they share a common worktable, so that a series of drilling and related operations can be accomplished in sequence (e.g., centering, drilling, reaming, tapping) simply by sliding the work part along the worktable from one spindle to the next. A related machine is the **multiple-spindle drill**, in which several drill spindles are connected together to drill multiple holes simultaneously into the work part.

In addition, **computer numerical control drill presses** are available to control the positioning of the holes in the work parts. These drill presses are often equipped with turrets to hold multiple tools that can be indexed under control of the NC program. The term **CNC turret drill** is used for these machine tools.

Workholding on a drill press is accomplished by clamping the part in a vise, fixture, or jig. A **vise** is a general-purpose workholding device possessing two jaws that grasp the work in position. A **fixture** is a workholding device that is usually custom-designed for the particular work part. The fixture can be designed to achieve higher accuracy in positioning the part relative to the machining operation, faster production rates, and greater operator convenience in use. A **jig** is a workholding device that is also specially designed for the work part. The distinguishing feature between a jig and a fixture is that the jig provides a means of guiding the tool during the drilling operation. A fixture does not have this tool guidance feature. A jig used for drilling is called a **drill jig**.

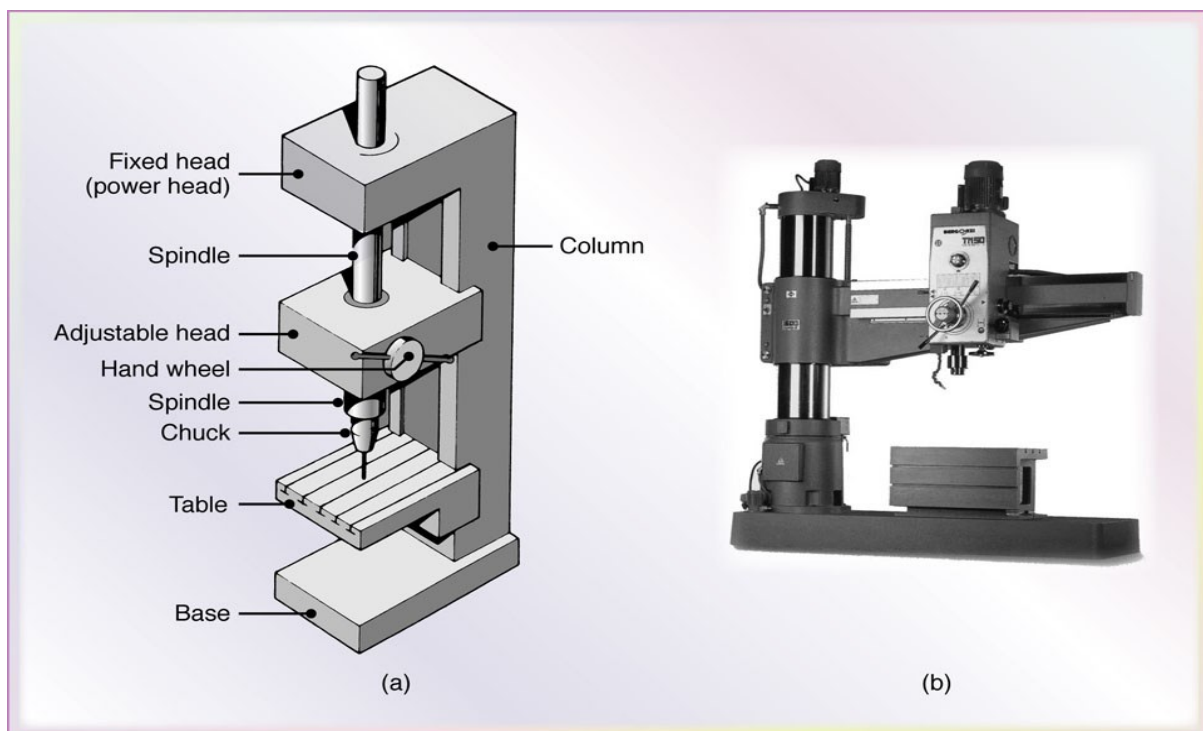

FIGURE 21.16 Figure 11(a). Vertical drilling machine; (b) Radial drill press. (Courtesy of Willis Machinery and Tools.)

21.4 MILLING

Milling is a machining operation in which a work part is fed past a rotating cylindrical tool with multiple cutting edges, as illustrated in Figure 21.2 (d) and (e). (In rare cases, a tool with one cutting edge, called a **fly-cutter**, is used). The axis of rotation of the cutting tool is perpendicular to the direction of feed. This orientation between the tool axis and the feed direction is one of the features that distinguishes milling from drilling. In drilling, the cutting tool is fed in a direction parallel to its axis of rotation. The cutting tool in milling is called a **milling cutter** and the cutting edges are called teeth. The conventional machine tool that performs this operation is a **milling machine**.

The geometric form created by milling is a plane surface. Other work geometries can be created either by means of the cutter path or the cutter shape. Owing to the variety of shapes possible and its high production rates, milling is one of the most versatile and widely used machining operations.

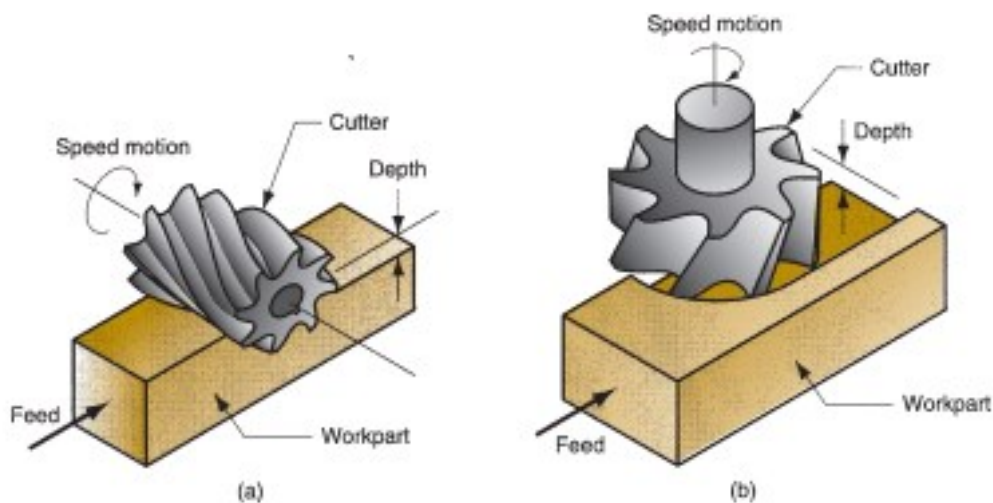

FIGURE 21.17: Two basic types of milling operations: (a) peripheral or plain milling and (b) face milling.

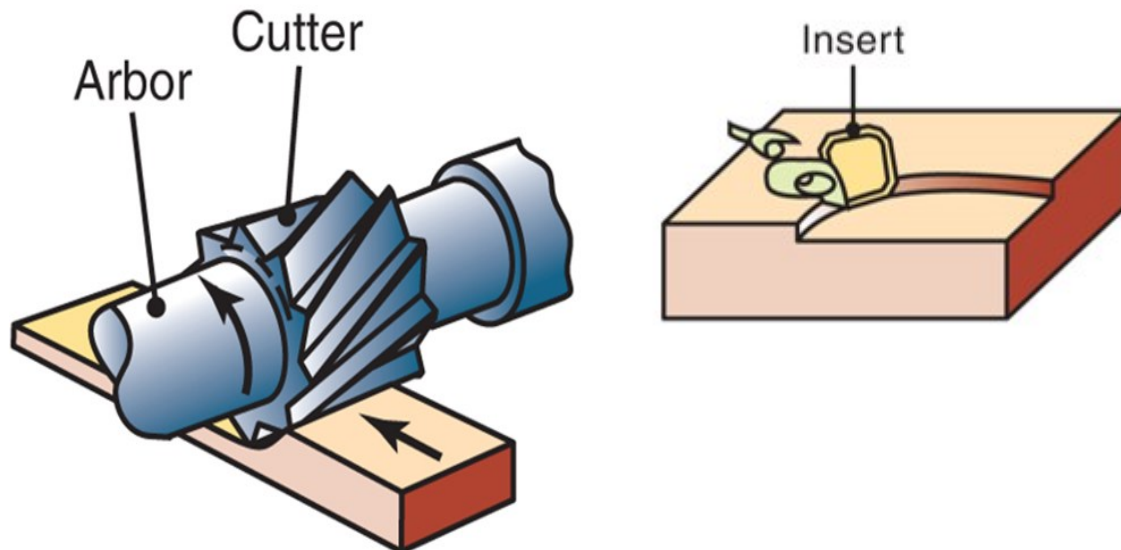

FIGURE 21.17: Schematic illustration of (a)(LEFT) peripheral milling;(b)RIGHT Face milling operation with cutter removed

Milling is an interrupted cutting operation; the teeth of the milling cutter enter and exit the work during each revolution. This interrupted cutting action subjects the teeth to a cycle of impact force and thermal shock on every rotation. The tool material and cutter geometry must be designed to withstand these conditions.

21.4.1 TYPES OF MILLING OPERATIONS

There are two basic types of milling operations, shown in Figure 21.17: (a) peripheral milling and (b) face milling. Most milling operations create geometry by generating the shape.

Peripheral Milling In peripheral milling, also called **plain milling**, the axis of the tool is parallel to the surface being machined, and the operation is performed by cutting edges on the outside periphery of the cutter. Several types of peripheral milling are shown in Figure 21.18:

(a) **Slab milling**. This is a basic form of peripheral milling in which the cutter width extends beyond the workpiece on both sides.

(b) **slotting**, also called slot milling, in which the width of the cutter is less than the workpiece width, creating a slot in the work—when the cutter is very

thin, this operation can be used to mill narrow slots or cut a work part in two, called saw milling;

(c) **side milling**, in which the cutter machines the side of the workpiece; (d) straddle milling, the same as side milling, only cutting takes place on both sides of the work; and

(e) **form milling**, in which the milling teeth have a special profile that determines the shape of the slot that is cut in the work. Form milling is therefore classified as a forming operation.

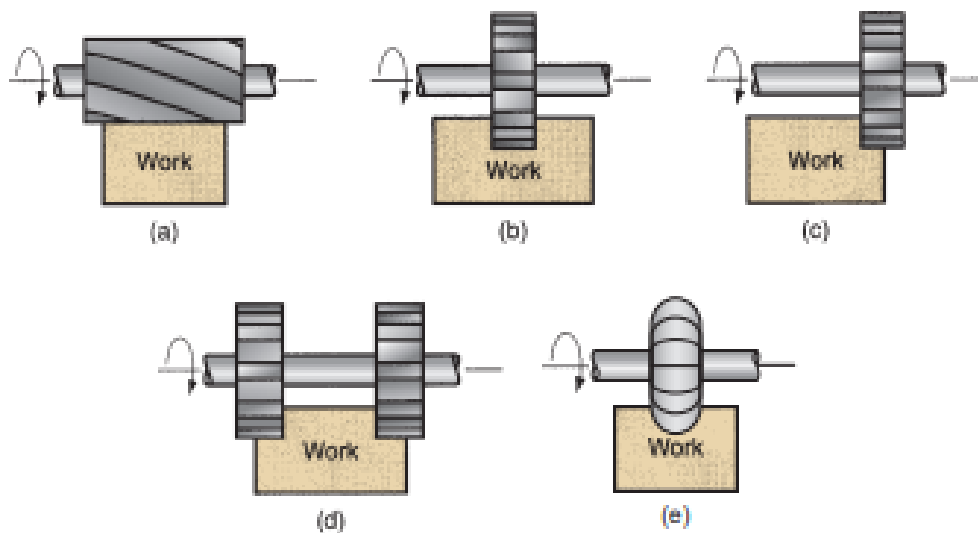

FIGURE 21.18 Peripheral milling: (a) slab milling, (b) slotting, (c) side milling, (d) straddle milling, and (e) form milling.

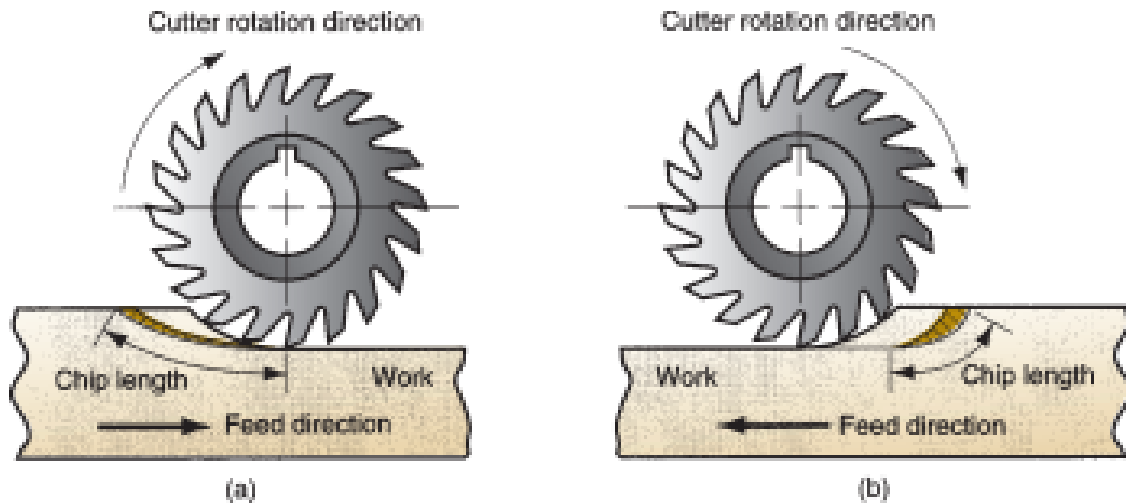
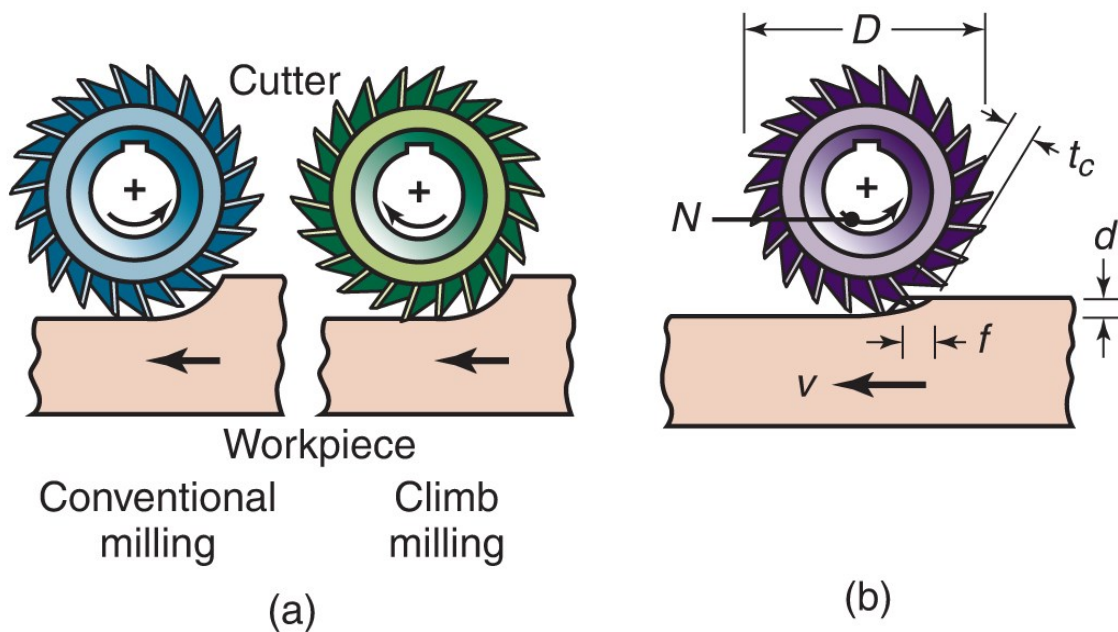

FIGURE 21.19: Two forms of peripheral milling operation with 20-tooth cutter: (a) up milling, and (b) down milling.



(a) Schematic illustration of conventional milling and climb milling; (b) Slab-milling operation showing depth of cut, d ; feed per tooth, f ; chip depth of cut, t_c , and workpiece speed, v .

In peripheral milling, the direction of cutter rotation distinguishes two forms of milling: up milling and down milling, illustrated in Figure 21.19. In **up milling**, also called **conventional milling**, the direction of motion of the

cutter teeth is opposite the feed direction when the teeth cut into the work. It is milling “against the feed.” In **down milling**, also called **climb milling**, the direction of cutter motion is the same as the feed direction when the teeth cut the work. It is milling “with the feed.”

The relative geometries of these two forms of milling result in differences in their cutting actions. In up milling, the chip formed by each cutter tooth starts out very thin and increases in thickness during the sweep of the cutter. In down milling, each chip starts out thick and reduces in thickness throughout the cut. The length of a chip in down milling is less than in up milling (the difference is exaggerated in the figure). This means that the cutter is engaged in the work for less time per volume of material cut, and this tends to increase tool life in down milling.

The cutting force direction is tangential to the periphery of the cutter for the teeth that are engaged in the work. In up milling, this has a tendency to lift the work part as the cutter teeth exit the material. In down milling, this cutter force direction is downward, tending to hold the work against the milling machine table.

Face Milling

In face milling, the axis of the cutter is perpendicular to the surface being milled, and machining is performed by cutting edges on both the end and outside periphery of the cutter. As in peripheral milling, various forms of face milling exist, several of which are shown in Figure 21.20.

(a) **Conventional face milling**, in which the diameter of the cutter is greater than the work part width, so the cutter overhangs the work on both sides;

(b) **partial face milling**, where the cutter overhangs the work on only one side;

(c) **End milling**, in which the cutter diameter is less than the work width, so a slot is cut into the part;

(d) **Profile milling**, a form of end milling in which the outside periphery of a flat part is cut;

(e) **Pocket milling**, another form of end milling used to mill shallow pockets into flat parts; and

(f) **Surface contouring**, in which a ball-nose cutter (rather than square-end cutter) is fed back and forth across the work along a curvilinear path at close intervals to create a three-dimensional surface form. The same basic cutter control is required to machine the contours of mold and die cavities, in which case the operation is called **die sinking**.

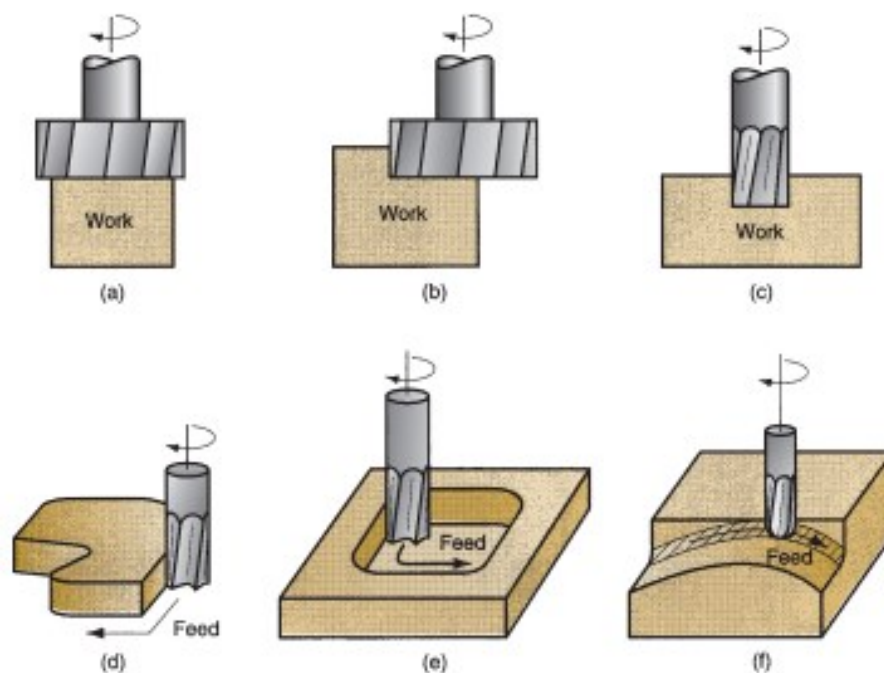

FIGURE 21.20 Face milling: (a) conventional face milling, (b) partial face milling, (c) end milling, (d) profile milling, (e) pocket milling, and (f) surface contouring.

21.4.2 CUTTING CONDITIONS IN MILLING

The cutting speed is determined at the outside diameter of a milling cutter. This can be converted to spindle rotation speed using a formula that should now be familiar:

$$N = \frac{v}{\pi D} \quad (21.13)$$

The feed f in milling is usually given as a feed per cutter tooth; called the **chip load**, it represents the size of the chip formed by each cutting edge. This can

be converted to feed rate by taking into account the spindle speed and the number of teeth on the cutter as follows:

$$f_r = Nn_t f \quad (21.14)$$

where f_r = feed rate, mm/min (in/min); N = spindle speed, rev/min; n_t = number of teeth on the cutter; and f = chip load in mm/tooth (in/tooth). Material removal rate in milling is determined using the product of the cross sectional area of the cut and the feed rate. Accordingly, if a slab-milling operation is cutting a workpiece with width w at a depth d , the material removal rate is

$$R_{MR} = wdf_r \quad (21.15)$$

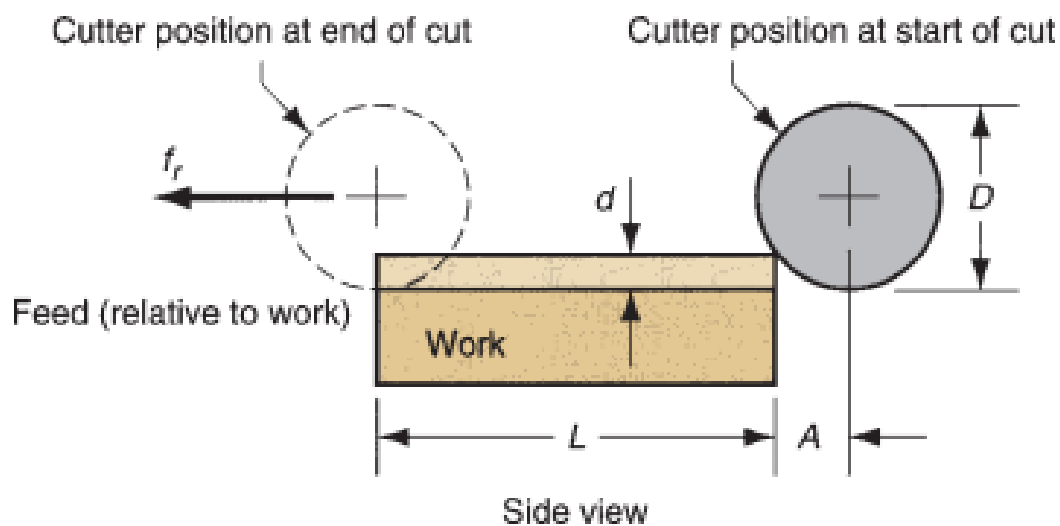

FIGURE 21.21 Slab (peripheral) milling showing entry of cutter into the workpiece.

This neglects the initial entry of the cutter before full engagement. Equation (21.15) can be applied to end milling, side milling, face milling, and other milling operations, making the proper adjustments in the computation of cross-sectional area of cut.

The time required to mill a workpiece of length L must account for the approach distance required to fully engage the cutter. First, consider the case of slab milling, Figure 21.21. To determine the time to perform a slab milling operation, the approach distance A to reach full cutter depth is given by

$$A = \sqrt{d(D - d)} \quad (21.16)$$

were d = depth of cut, mm (in); and D = diameter of the milling cutter, mm (in). The time T_m in which the cutter is engaged milling the workpiece is therefore

$$T_m = \frac{L+A}{f_r} \quad (21.17)$$

For face milling, consider the two possible cases pictured in Figure 21.22. The first case is when the cutter is centered over a rectangular workpiece as in Figure 21.22(a). The cutter feeds from right to left across the workpiece. In order for the cutter to reach the full width of the work, it must travel an approach distance given by

$$A = 0.5(D - \sqrt{D^2 - w^2}) \quad (21.18)$$

where D = cutter diameter, mm (in) and w = width of the workpiece, mm (in). If $D = w$, then Equation (21.18) reduces to $A = 0.5D$. And if $D < w$, then a slot is cut into the work and $A = 0.5D$. The second case is when the cutter is offset to one side of the work, as in Figure 21.22(b). In this case, the approach distance is given by

$$A = \sqrt{w(D - w)} \quad (21.19)$$

where w = width of the cut, mm (in). In either case, the machining time is given by

$$T_m = \frac{L+A}{f_r} \quad (21.20)$$

It should be emphasized in all of these milling scenarios that T_m represents the time the cutter teeth are engaged in the work, making chips. Overtravel distances are usually added at the beginning and end of each cut to allow

access to the work for loading and unloading. Thus the actual duration of the cutter feed motion is likely to be greater than T_m .

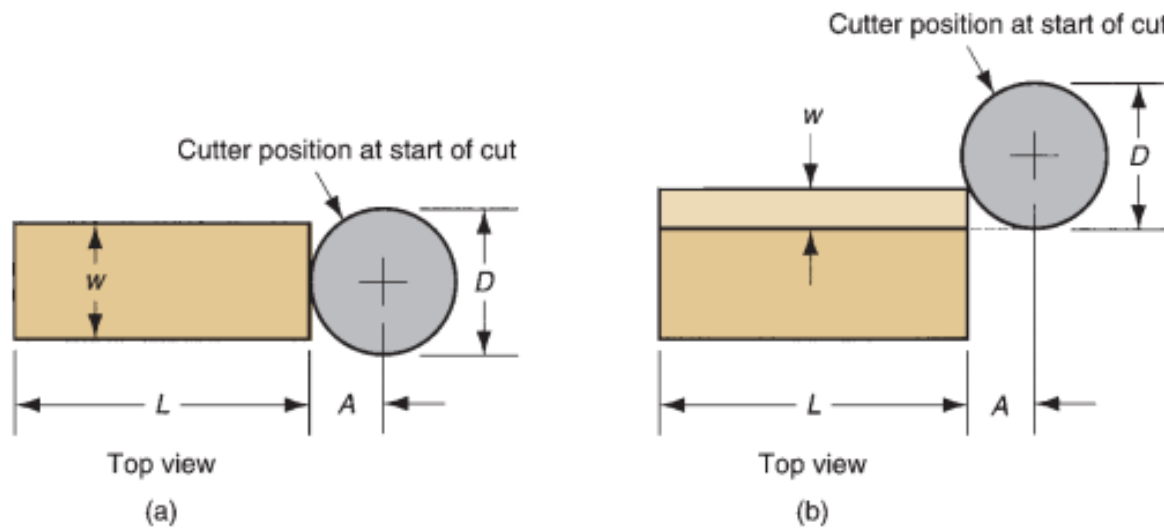

FIGURE 21.22 Face milling showing approach and overtravel distances for two cases: (a) when cutter is centered over the workpiece, and (b) when cutter is offset to one side over the work.

Example 21.3 Machining time in peripheral milling

A peripheral milling operation is performed on a rectangular workpiece that is 320 mm long by 60 mm wide by 56 mm thick. The 65-mm-diameter milling cutter has 4 teeth, is 80 mm long, and overhangs the work on either side by 10 mm. The operation reduces the thickness of the piece to 50 mm. Cutting speed = 0.50 m/s and chip load = 0.24 mm/tooth. Determine (a) machining time and (b) metal removal rate once the cutter reaches full depth.

Solution:

$$(a) \quad N = v/\pi D = 0.50(10^3)/\pi(65) = 2.45 \text{ rev/s}$$

$$f_r = Nn_t f = 2.45(4)(0.24) = 2.35 \text{ mm/s}$$

$$\text{Depth of cut } d = 56 - 50 = 6 \text{ mm}$$

$$A = (6(65 - 6))^{0.5} = 18.8 \text{ mm}$$

$$T_m = (320 + 18.8)/2.35 = 144.2 \text{ s} = \mathbf{2.40 \text{ min}}$$

$$(b) \quad R_{MR} = wdf_r = 60(6)(2.35) = \mathbf{846 \text{ mm}^3/\text{s}}$$

21.4.3 MILLING MACHINES

Milling machines must provide a rotating spindle for the cutter and a table for fastening, positioning, and feeding the work part. Various machine tool designs satisfy these requirements. To begin with, milling machines can be classified as horizontal or vertical.

A **horizontal milling machine** has a horizontal spindle, and this design is well suited for performing peripheral milling (e.g., slab milling, slotting, side and straddle milling) on work parts that are roughly cube shaped. A **vertical milling machine** has a vertical spindle, and this orientation is appropriate for face milling, end milling, surface contouring, and die-sinking on relatively flat work parts. Other than spindle orientation, milling machines can be classified into the following types: (1) *knee-and-column*, (2) *bed type*, (3) *planer type*, (4) *tracer mills*, and (5) *CNC milling machines*. The **knee-and-column milling machine** is the basic machine tool for milling. It derives its name from the fact that its two main components are a **column** that supports the spindle, and a knee (roughly resembling a human **knee**) that supports the worktable.

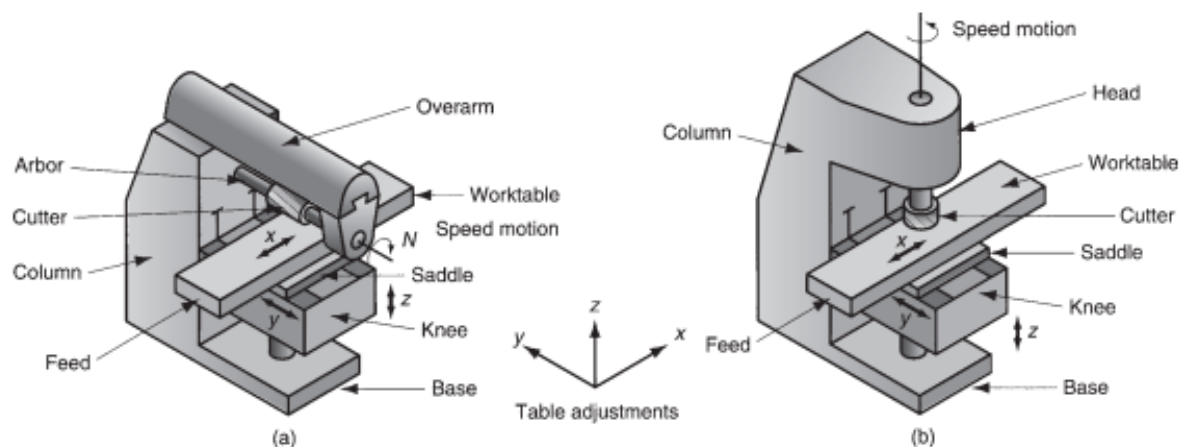

FIGURE 21.23: Two basic types of knee-and-column milling machine: (a) horizontal and (b) vertical.

It is available as either a horizontal or a vertical machine, as illustrated in **Figure 21.23**. In the horizontal version, an arbor usually supports the cutter. The **arbor** is basically a shaft that holds the milling cutter and is driven by the spindle. An overarm is provided on horizontal machines to

support the arbor. On vertical knee-and-column machines, milling cutters can be mounted directly in the spindle without an arbor.

One of the features of the knee-and-column milling machine that makes it so versatile is its capability for worktable feed movement in any of the x–y–z axes. The worktable can be moved in the x-direction, the saddle can be moved in the y-direction, and the knee can be moved vertically to achieve the z-movement.

Two special knee-and-column machines should be identified. One is the **universal** milling machine, **Figure 21.24(a)**, which has a table that can be swiveled in a horizontal plane (about a vertical axis) to any specified angle. This facilitates the cutting of angular shapes and helixes on work parts. Another special machine is the **ram mill**,

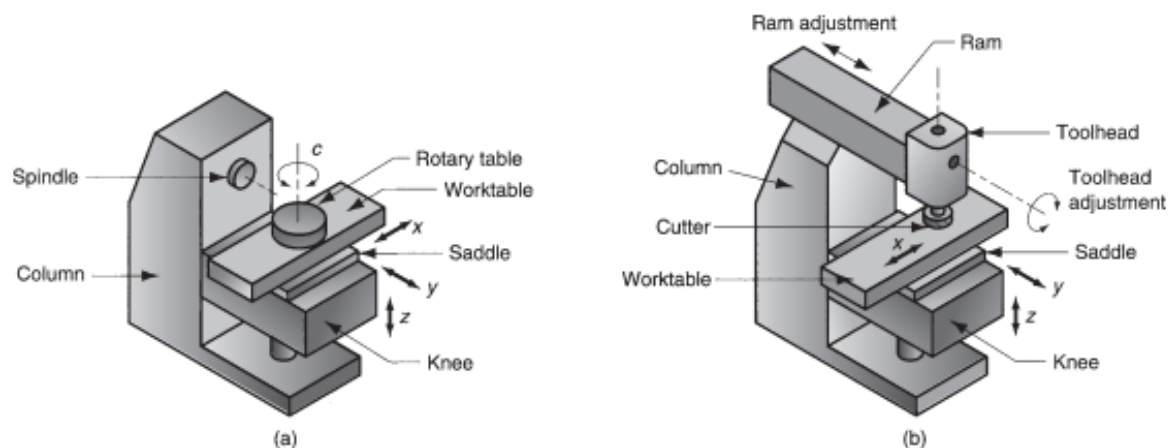

FIGURE 21.24 Special types of knee-and-column milling machine: (a) universal — overarm, arbor and cutter omitted for clarity; and (b) ram type.

Figure 21.24(b), in which the toolhead containing the spindle is located on the end of a horizontal ram; the ram can be adjusted in and out over the worktable to locate the cutter relative to the work. The toolhead can also be swiveled to achieve an angular orientation of the cutter with respect to the work. These features provide considerable versatility in machining a variety of work shapes.

Bed-type milling machines are designed for high production. They are constructed with greater rigidity than knee-and-column machines, thus permitting them to achieve heavier feed rates and depths of cut needed for

high material removal rates. The characteristic construction of the bed-type milling machine is shown in Figure 21.25. The worktable is mounted directly to the bed of the machine tool, rather than using the less rigid knee-type design. This construction limits the possible motion of the table to longitudinal feeding of the work past the milling cutter. The cutter is mounted in a spindle head that can be adjusted vertically along the machine column. Single spindle bed machines are called **simplex** mills, as in Figure 21.25, and are available in either horizontal or vertical models. **Duplex** mills use two spindle heads. The heads are usually positioned horizontally on opposite sides of the bed to perform simultaneous operations during one feeding pass of the work. **Triplex** mills add a third spindle mounted vertically over the bed to further increase machining capability.

Planer type mills are the largest milling machines. Their general appearance and construction are those of a large planer (*see Figure 21.31*); the difference is that milling is performed instead of planing. Accordingly, one or more milling heads are substituted for the single-point cutting tools used on planers, and the motion of the work past the tool is a feed rate motion rather than a cutting speed motion. Planer mills are built to machine very large parts. The worktable and bed of the machine are heavy and relatively low to the ground, and the milling heads are supported by a bridge structure that spans across the table.

A tracer mill, also called a **profiling mill**, is designed to reproduce an irregular part geometry that has been created on a template. Using either manual feed by a human operator or automatic feed by the machine tool, a tracing probe is controlled to follow the template while a milling head duplicates the path taken by the probe to machine the desired shape. Tracer mills are of two types: (1) **x-y tracing**, in which the contour of a flat template is profiled milled using two-axis control; and (2) **x-y-z tracing**, in which the probe follows a three dimensional pattern using three-axis control. Tracer mills have been used for creating shapes that cannot easily be generated by a simple feeding action of the work against the milling cutter. Applications include molds and dies. In recent years, many of these applications have been taken over by computer numerical control (CNC) milling machines.

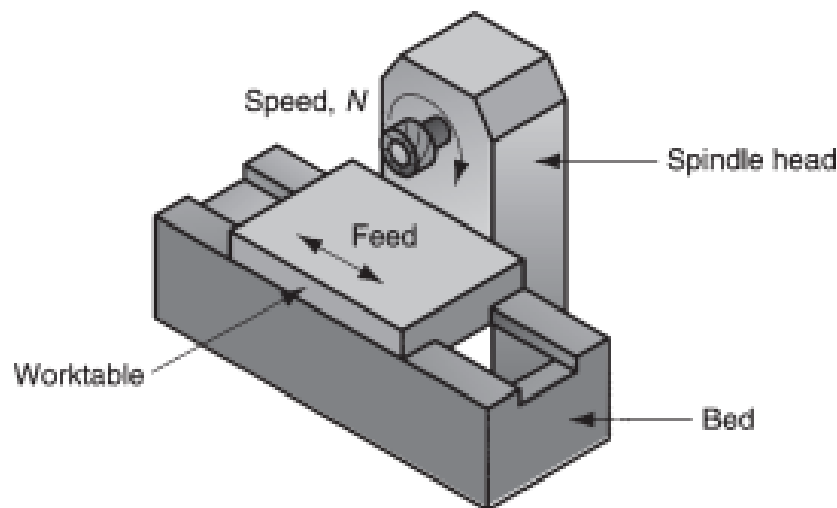

FIGURE 21.25 Simplex bed type milling machine horizontal spindle.

CNC milling machines are milling machines in which the cutter path is controlled by alphanumeric data rather than a physical template. They are especially suited to profile milling, pocket milling, surface contouring, and die sinking operations, in which two or three axes of the worktable must be simultaneously controlled to achieve the required cutter path. An operator is normally required to change cutters as well as load and unload work parts.

21.5 MACHINING CENTERS AND TURNING CENTERS

A machining center, illustrated in Figure 21.26, is a highly automated machine tool capable of performing multiple machining operations under computer numerical control in one setup with minimal human attention. Workers are needed to load and unload parts, which usually takes considerable less time than the machine cycle time, so one worker may be able to tend more than one machine. Typical operations performed on a machining center are milling and drilling, which use rotating cutting tools. The typical features that distinguish a machining center from conventional machine tools and make it so productive include:

- **Multiple operations in one setup.** Most work parts require more than one operation to completely machine the specified geometry. Complex

parts may require dozens of separate machining operations, each requiring its own machine tool, setup, and cutting tool. Machining centers are capable of performing most or all of the operations at one location, thus minimizing setup time and production lead time.

- **Automatic tool changing.** To change from one machining operation to the next, the cutting tools must be changed. This is done on a machining center under CNC program control by an automatic tool-changer designed to exchange cutters between the machine tool spindle and a **tool storage carousels**. Capacities of these carousels commonly range from 16 to 80 cutting tools. The machine in Figure 21.26 has two storage carousels on the left side of the column.
- **Pallet shuttles.** Some machining centers are equipped with pallet shuttles, which are automatically transferred between the spindle position and the loading station, as shown in Figure 21.26. Parts are fixtured on pallets that are attached to the shuttles. In this arrangement, the operator can be unloading the previous part and loading the next part while the machine tool is engaged in machining the current part. Non-productive time on the machine is thereby reduced.
- Automatic work part positioning. Many machining centers have more than three axes. One of the additional axes is often designed as a rotary table to position the part at some specified angle relative to the spindle. The rotary table permits the cutter to perform machining on four sides of the part in a single setup. Machining centers are classified as horizontal, vertical, or universal. The designation refers to spindle orientation. Horizontal machining centers (HMCs) normally machine cube-shaped parts, in which the four vertical sides of the cube can be accessed by the cutter. Vertical machining centers (VMCs) are suited to flat parts on which the tool can machine the top surface. Universal machining centers have workheads that swivel their spindle axes to any angle between horizontal and vertical, as in Figure 21.26.

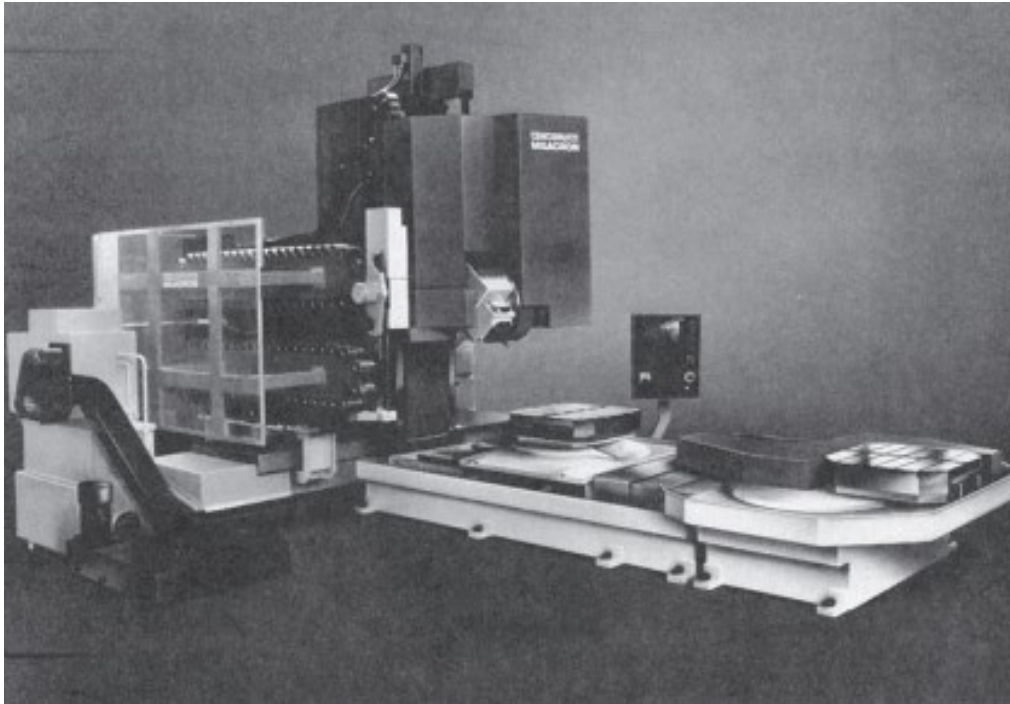

FIGURE 21.26 A universal machining center. Capability to orient the workhead makes this a five-axis machine. (Courtesy of Cincinnati Milacron.)

Success of CNC machining centers led to the development of CNC turning centers. A **modern CNC turning center**, Figure 21.27, is capable of performing various turning and related operations, contour turning, and automatic tool indexing, all under computer control. In addition, the most sophisticated turning centers can accomplish (1) work part gaging (checking key dimensions after machining), (2) tool monitoring (sensors to indicate when the tools are worn), (3) automatic tool changing when tools become worn, and even (4) automatic work part changing at the completion of the work cycle [14]. Another type of machine tool related to machining centers and turning centers is the CNC mill-turn center.

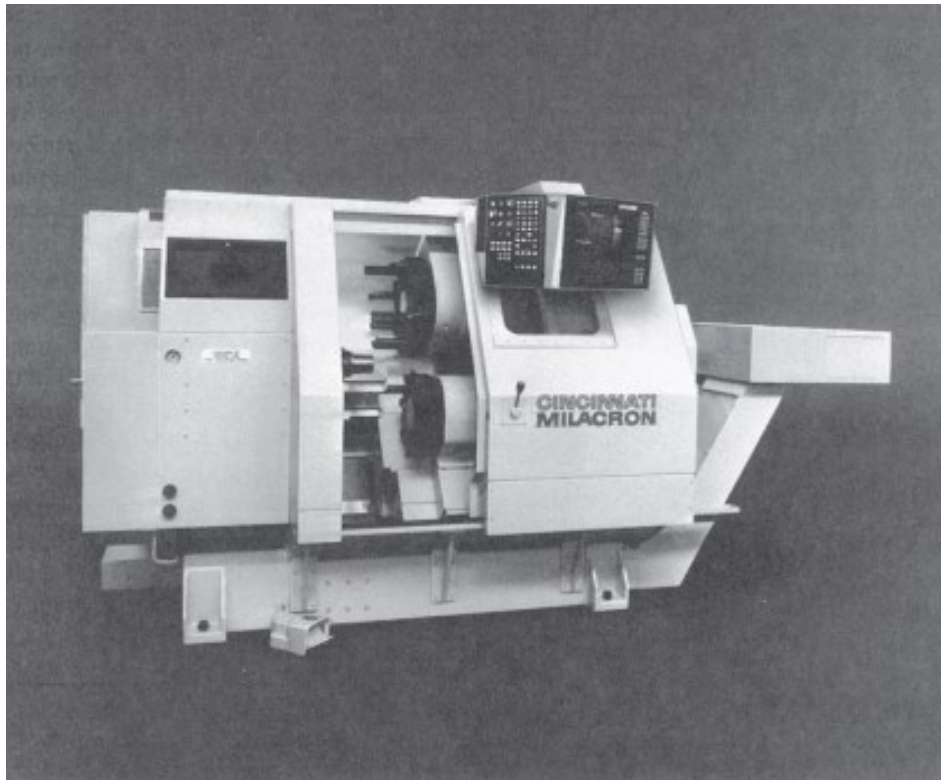

FIGURE 21.27: CNC four-axis turning center. (Courtesy of Cincinnati Milacron).

This machine has the general configuration of a turning center; in addition, it can position a cylindrical work part at a specified angle so that a rotating cutting tool (e.g., milling cutter) can machine features into the outside surface of the part, as illustrated in Figure 21.28. An ordinary turning center does not have the capability to stop the work part at a defined angular position, and it does not possess rotating tool spindles.

Further progress in machine tool technology has taken the mill-turn center one-step further by integrating additional capabilities into a single machine. The additional capabilities include (1) combining milling, drilling, and turning with grinding, welding, and inspection operations, all in one machine tool; (2) using multiple spindles simultaneously, either on a single workpiece or two different workpieces; and (3) automating the part handling function by adding industrial robots to the machine [2], [20]. The terms ***multitasking machine*** and ***multifunction machine*** are sometimes used for these machine tools.

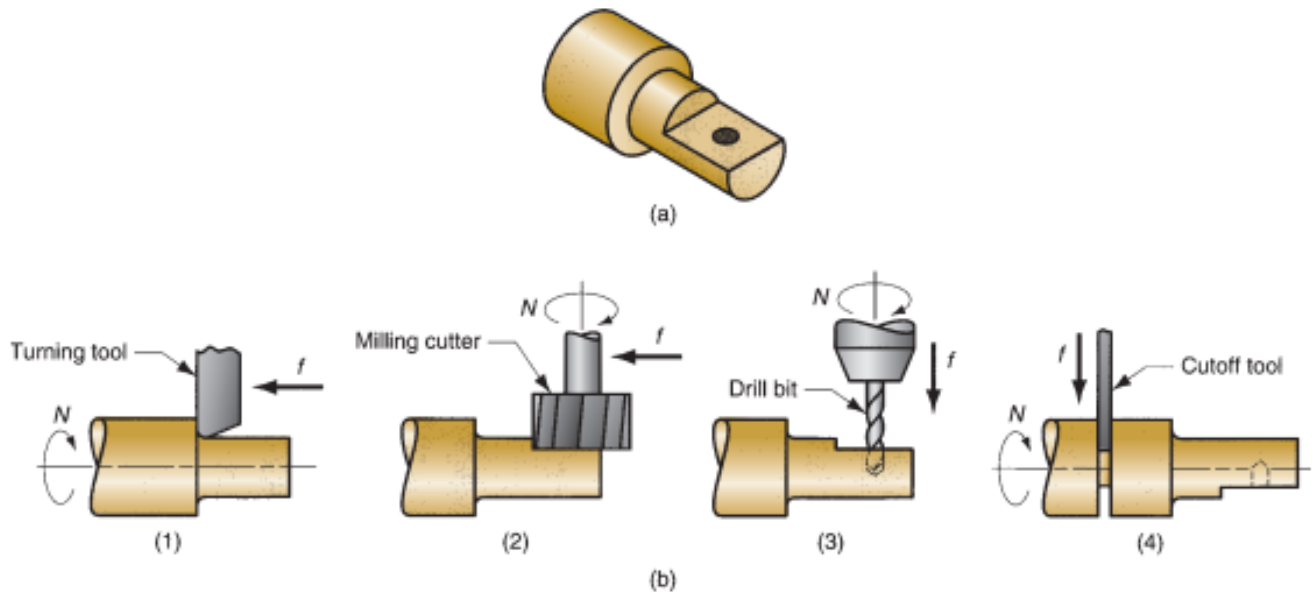

FIGURE 21.28: Operation of a mill-turn center: (a) example part with turned, milled, and drilled surfaces; and (b) sequence of operations on a mill-turn center: (1) turn second diameter, (2) mill flat with part in programmed angular position, (3) drill hole with part in same programmed position, and (4) cutoff.

21.6 OTHER MACHINING OPERATIONS

In addition to turning, drilling, and milling, several other machining operations should be included in this survey: (1) shaping and planing, (2) broaching, and (3) sawing.

21.6.1 SHAPING AND PLANING

Shaping and planing are similar operations, both involving the use of a single-point cutting tool moved linearly relative to the work part. In conventional shaping and planing, a straight, flat surface is created by this action. The difference between the two operations is illustrated in Figure 21.29. In shaping, the speed motion is accomplished by moving the cutting tool; while in planing, the speed motion is accomplished by moving the work part. Cutting tools used in shaping and planing are single-point tools. Unlike turning, interrupted cutting occurs in shaping and planing, subjecting the tool to an impact loading upon entry into the work. In addition, these machine tools are limited to low speeds due to their start-and-stop motion. The conditions normally dictate use of high-speed steel cutting tools.

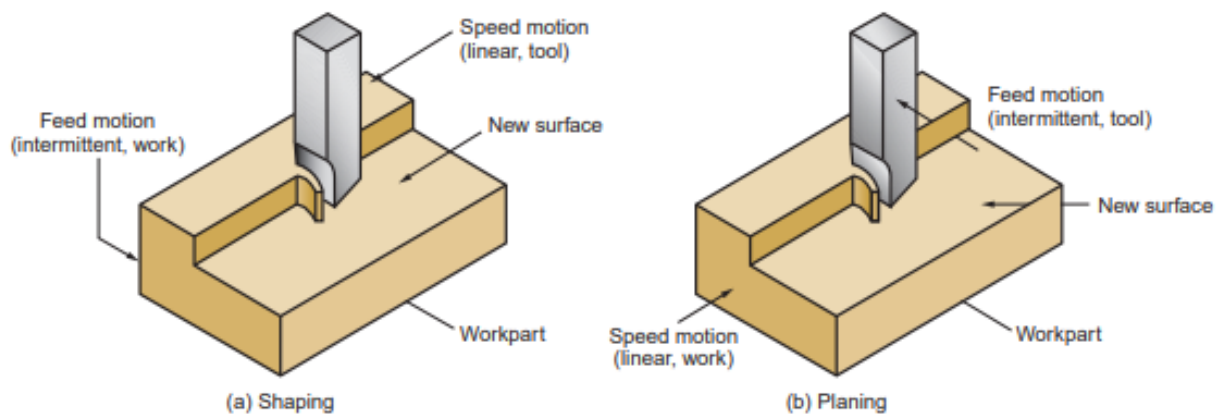

FIGURE 21.29: (a) Shaping, and (b) planing

Shaping Shaping is performed on a machine tool called a *shaper*, Figure 21.30. The components of the shaper include a ram, which moves relative to a column to provide the cutting motion, and a worktable that holds the part and accomplishes the feed motion.

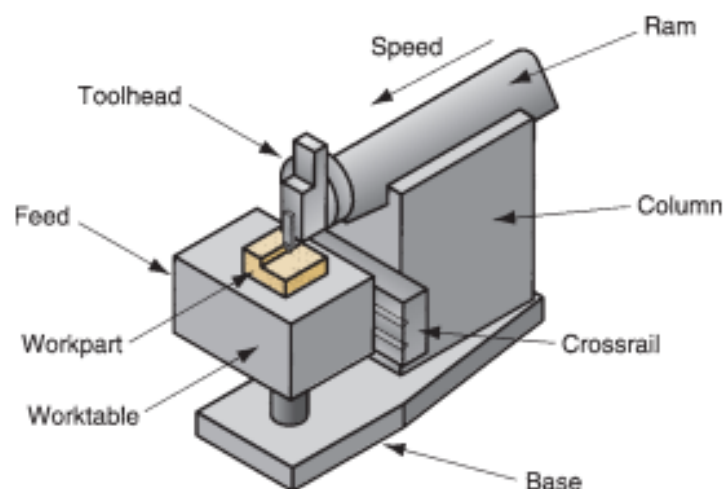

FIGURE 21.30: Components of a shaper.

The motion of the ram consists of a forward stroke to achieve the cut, and a return stroke during which the tool is lifted slightly to clear the work and then reset for the next pass. On completion of each return stroke, the worktable is advanced laterally relative to the ram trajectory to feed the part. Feed is

specified in mm/stroke (in/stroke). The drive mechanism for the ram can be either hydraulic or mechanical. Hydraulic drive has greater flexibility in adjusting the stroke length and a more uniform speed during the forward stroke, but it is more expensive than a mechanical drive unit. Both mechanical and hydraulic drives are designed to achieve higher speeds on the return (noncutting) stroke than on the forward (cutting) stroke, thereby increasing the proportion of time spent cutting.

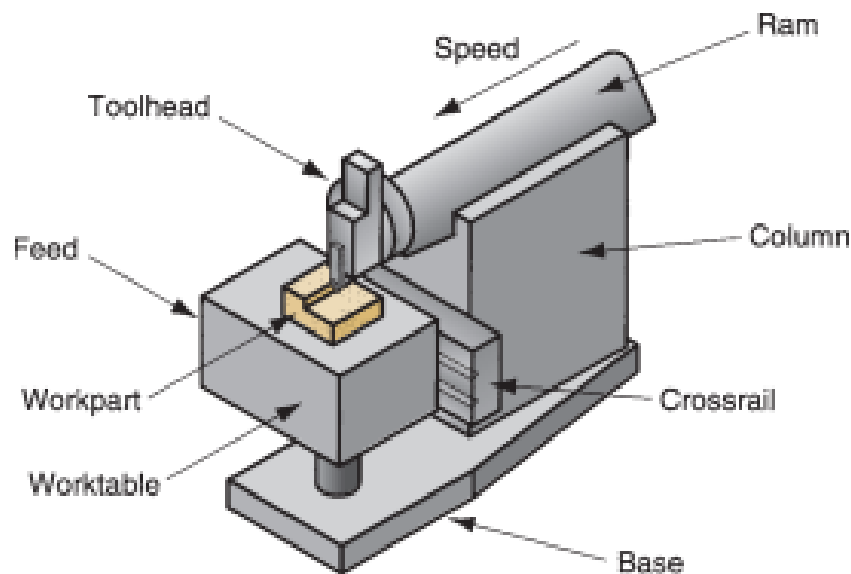

FIGURE 21.30 Components of a shaper.

Planing The machine tool for planing is a planer. Cutting speed is achieved by a reciprocating worktable that moves the part past the single point cutting tool. The construction and motion capability of a planer permit much larger parts to be machined than on a shaper. Planers can be classified as open side planers or double-column planers. The **open-side planer**, also known as a **single-column planer**, Figure 21.31, has a single column supporting the cross-rail on which a toolhead is mounted. Another toolhead can also be mounted and fed along the vertical column. Multiple toolheads permit more than one cut to be taken on each pass. At the completion of each stroke, each toolhead is moved relative to the cross-rail (or column) to achieve the

intermittent feed motion. The configuration of the open-side planer permits very wide work parts to be machined.

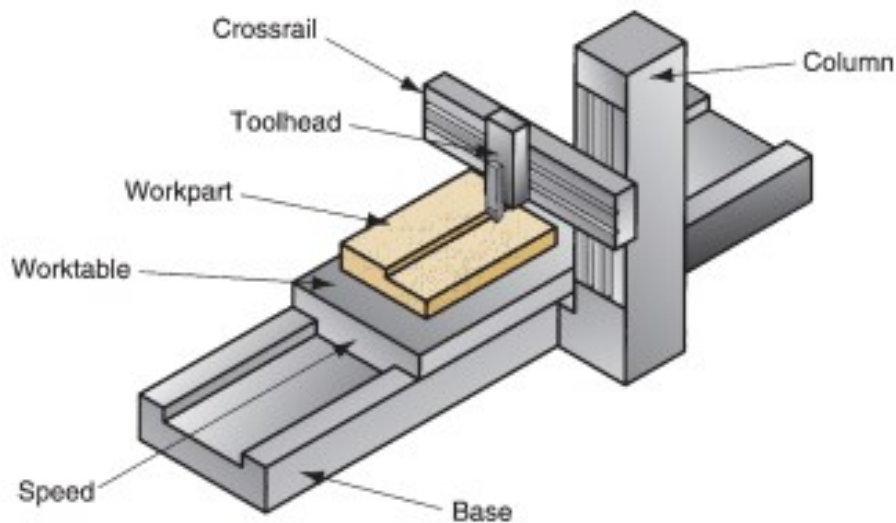

FIGURE 21.31: Open side planer.

A **double-column planer** has two columns, one on either side of the base and worktable. The columns support the cross-rail, on which one or more tool heads are mounted. The two columns provide a more rigid structure for the operation; however, the two columns limit the width of the work that can be handled on this machine.

Shaping and planing can be used to machine shapes other than flat surfaces. The restriction is that the cut surface must be straight. This allows the cutting of grooves, slots, gear teeth, and other shapes as illustrated in Figure 21.32. Special machines and tool geometries must be specified to cut some of these shapes. An important example is the **gear shaper**, a vertical shaper with a specially designed rotary feed table and synchronized tool head used to generate teeth on spur gears.

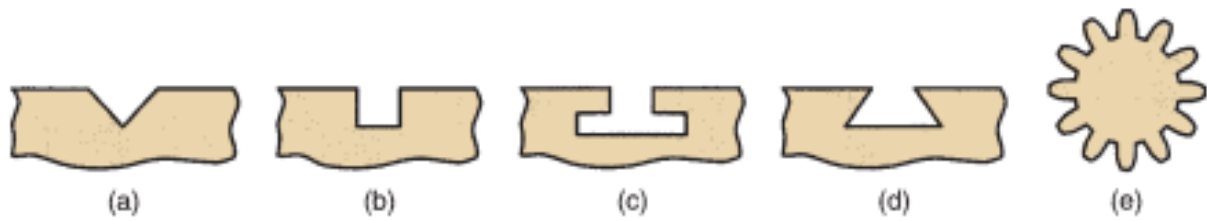

FIGURE 21.32: Types of shapes that can be cut by shaping and planing: (a) V-groove, (b) square groove, (c) T-slot, (d) dovetail slot, and (e) gear teeth.

21.6.2 BROACHING

Broaching is performed using a multiple teeth cutting tool by moving the tool linearly relative to the work in the direction of the tool axis, as in Figure 21.33. The machine tool is called a **broaching machine**, and the cutting tool is called a **broach**. In certain jobs for which broaching can be used, it is a highly productive method of machining. Advantages include good surface finish, close tolerances, and a variety of work shapes. Owing to the complicated and often custom-shaped geometry of the broach, tooling is expensive.

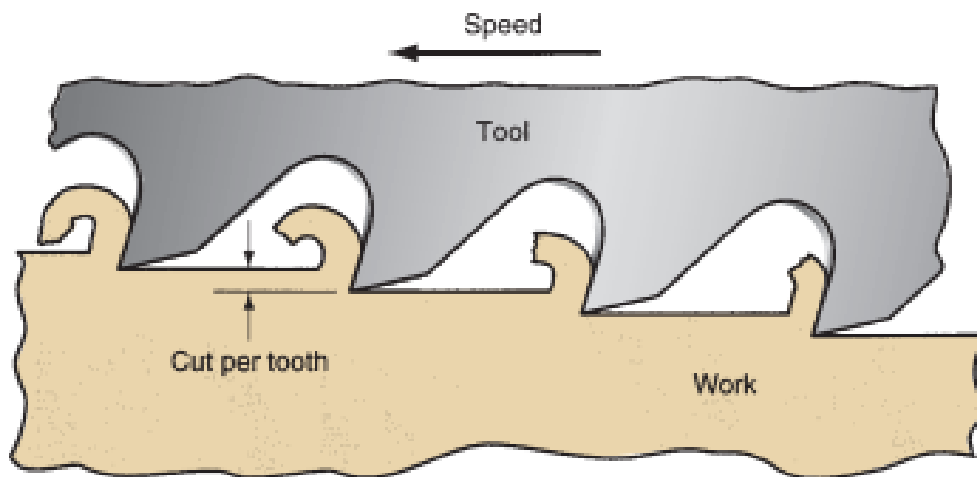

FIGURE 21.33: The broaching operation.

There are two principal types of broaching: external (also called surface broaching) and internal. **External broaching** is performed on the outside surface of the work to create a certain cross-sectional shape on the surface. Figure 21.34(a) shows some possible cross sections that can be formed by external broaching. **Internal broaching** is accomplished on the internal surface of a hole in the part. Accordingly, a starting hole must be present in the part so as to insert the broach at the beginning of the broaching stroke. Figure 21.34(b) indicates some of the shapes that can be produced by internal broaching.

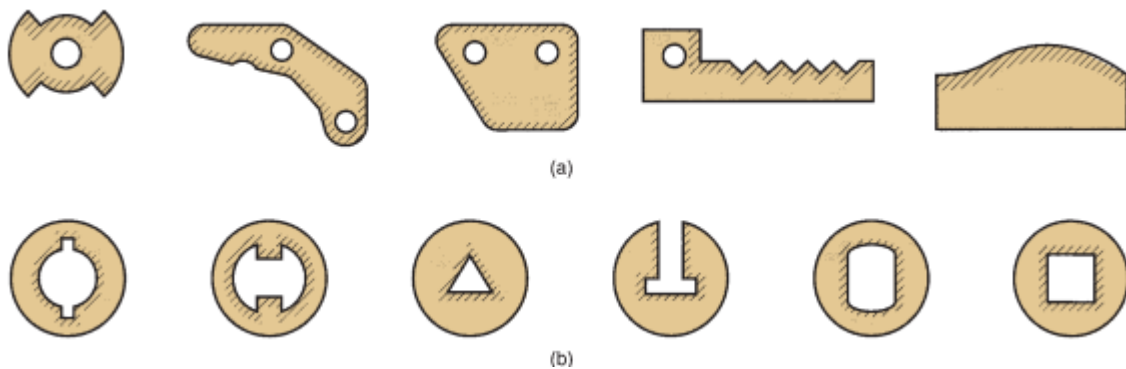

FIGURE 21.34: Work shapes that can be cut by: (a) external broaching, and (b) internal broaching. Cross-hatching indicates the surfaces broached.

The basic function of a broaching machine is to provide a precise linear motion of the tool past a stationary work position, but there are various ways in which this can be done. Most broaching machines can be classified as either vertical or horizontal machines. The **vertical broaching machine** is designed to move the broach along a vertical path, while the horizontal broaching machine has a horizontal tool path. Most broaching machines pull the broach past the work. However, there are exceptions to this pull action. One exception is a relatively simple type called a **broaching press**, used only for internal broaching, that pushes the tool through the work part. Another exception is the **continuous broaching machine**, in which the work parts are fixtured to an endless belt loop and moved past a stationary broach.

Because of its continuous operation, this machine can be used only for surface broaching.

21.6.3 SAWING

Sawing is a process in which a narrow slit is cut into the work by a tool consisting of a series of narrowly spaced teeth. Sawing is normally used to separate a work part into two pieces, or to cut off an unwanted portion of a part. These operations are often referred to as cutoff operations. Since many factories require cutoff operations at some point in the production sequence, sawing is an important manufacturing process. In most sawing operations, the work is held stationary and the saw blade is moved relative to it. There are three basic types of sawing, as in Figure 21.35, according to the type of blade motion involved: (a) hacksawing, (b) bandsawing, and (c) circular sawing. Hacksawing, Figure 21.35(a), involves a linear reciprocating motion of the saw against the work. This method of sawing is often used in cutoff operations. Cutting is accomplished only on the forward stroke of the saw blade. Because of this intermittent cutting action, hacksawing is inherently less efficient than the other sawing methods, both of which are continuous. The hacksaw blade is a thin straight tool with cutting teeth on one edge. Hacksawing can be done either manually or with a power hacksaw. A power hacksaw provides a drive mechanism to operate the saw blade at a desired speed; it also applies a given feed rate or sawing pressure.

Bandsawing involves a linear continuous motion, using a **bandsaw blade** made in the form of an endless flexible loop with teeth on one edge. The sawing machine is a **bandsaw**, which provides a pulley-like drive mechanism to continuously move and guide the bandsaw blade past the work. Bandsaws are classified as vertical or horizontal. The designation refers to the direction of saw blade motion during cutting. Vertical bandsaws are used for cutoff as well as other operations such as contouring and slotting. **Contouring** on a bandsaw involves cutting a part profile from flat stock.

Slotting is the cutting of a thin slot into a part, an operation for which bandsawing is well suited. Contour sawing and slotting are operations in which the work is fed into the saw blade.

Vertical bandsaw machines can be operated either manually, in which the operator guides and feeds the work past the bandsaw blade, or automatically, in which the work is power fed past the blade. Recent innovations in bandsaw design have permitted the use of CNC to perform contouring of complex outlines. Some of the details of the vertical bandsawing operation are illustrated in Figure 21.35(b). Horizontal bandsaws are normally used for cutoff operations as alternatives to power hacksaws.

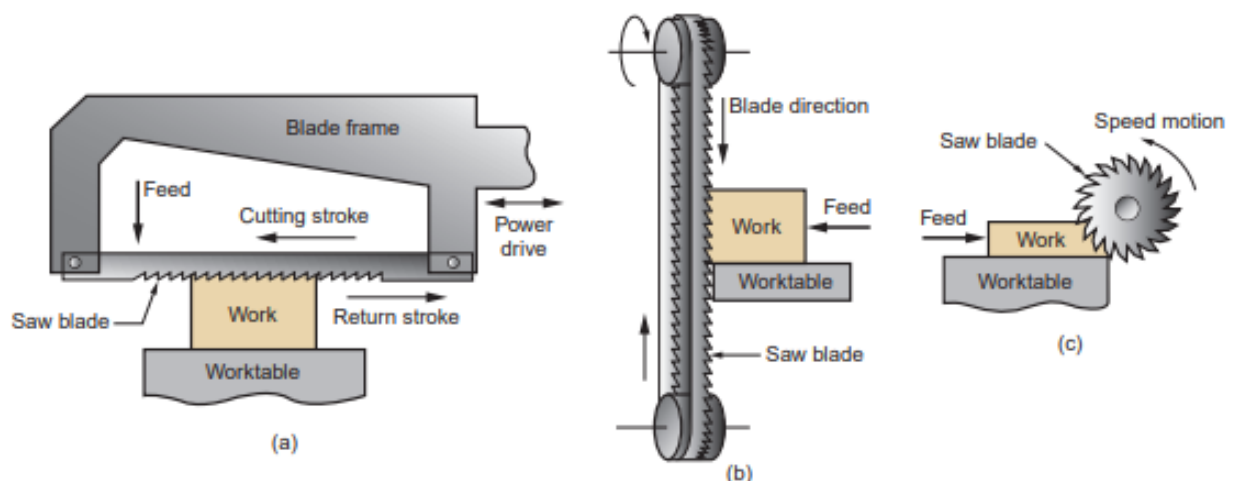

FIGURE 21.35: Three types of sawing operations: (a) power hacksaw, (b) bandsaw (vertical), and (c) circular saw.

Circular sawing, Figure 21.35(c), uses a rotating saw blade to provide a continuous motion of the tool past the work. Circular sawing is often used to cut long bars, tubes, and similar shapes to specified length. The cutting action is similar to a slot milling operation, except that the saw blade is thinner and contains many more cutting teeth than a slot milling cutter. Circular sawing machines have powered spindles to rotate the saw blade and a feeding mechanism to drive the rotating blade into the work.

Two operations related to circular sawing are abrasive cutoff and friction sawing. In ***abrasive cutoff***, an abrasive disk is used to perform cutoff operations on hard materials that would be difficult to saw with a conventional saw blade. In ***friction sawing***, a steel disk is rotated against the work at very high speeds, resulting in friction heat that causes the material to soften sufficiently to permit penetration of the disk through the work. The cutting speeds in both of these operations are much faster than in circular sawing.

21.7 MACHINING OPERATIONS FOR SPECIAL GEOMETRIES

One of the reasons for the technological importance of machining is its capability to produce unique geometric features such as screw threads and gear teeth. This section discusses the cutting processes that are used to accomplish these shapes, most of which are adaptations of machining operations discussed earlier in the lecture.

21.7.1 SCREW THREADS

Threaded hardware components are widely used as fasteners in assembly (screws, bolts, and nuts,) and for transmission of motion in machinery (e.g., lead screws in positioning systems). Threads can be defined as grooves that form a spiral around the outside of a cylinder (external threads) or the inside of a round hole (internal threads). Thread rolling is by far the most common method for producing external threads, but the process is not economical for low production quantities and the work metal must be ductile. Metallic threaded components can also be made by casting, especially investment casting and die casting, and plastic parts with threads can be injection molded. Finally, threaded components can be machined, and this is the topic addressed here. The discussion is organized into external and internal thread machining.

External Threads The simplest and most versatile method of cutting an external thread on a cylindrical work part is **single-point threading**, which employs a single point cutting tool on a lathe. This process is illustrated in Figure 21.6(g). The starting diameter of the workpiece is equal to the major diameter of the screw thread. The tool must have the profile of the thread groove, and the lathe must be capable of maintaining the same relationship between the tool and the workpiece on successive passes in order to cut a consistent spiral. This relationship is achieved by means of the lathe's lead screw (see Figure 21.7). More than one turning pass is usually required. The first pass takes a light cut; the tool is then retracted and rapidly traversed back to the starting point; and each ensuing pass traces the same spiral using ever greater depths of cut until the desired form of the thread groove has been established. Single-point threading is suitable for low or even medium production quantities, but less time-consuming methods are more economical for high production.

An alternative to using a single-point tool is a **threading die**, shown in Figure 21.36. To cut an external thread, the die is rotated around the starting cylindrical stock of the proper diameter, beginning at one end and proceeding to the other end. The cutting teeth at the opening of the die are tapered so that the starting depth of cut is less at the beginning of the operation, finally reaching full thread depth at the trailing side of the die. The pitch of the threading die teeth determines the pitch of the screw that is being cut. The die in Figure 21.36 has a slit that allows the size of the opening to be adjusted to compensate for tool wear on the teeth or to provide for minor differences in screw size. Threading dies cut the threads in a single pass rather than multiple passes as in single-point threading.

Threading dies are typically used in manual operations, in which the die is fixed in a holder that can be rotated by hand. If the workpiece has a head or other obstacle at the other end, the die must be unwound from the screw just created in order to remove it. This is not only time consuming, but it also risks possible damage to the thread surfaces. In mechanized threading operations, cycle times can be reduced by using self-opening threading dies,

which are designed with an automatic device that opens the cutting teeth at the end of each cut. This eliminates the need to unwind the die from the work and avoids possible damage to the threads. Self-opening dies are equipped with four sets of cutting teeth, similar to the threading die in Figure 21.36, except that the teeth can be adjusted and removed for resharpening, and the toolholder mechanism possesses the self-opening feature. Different sets of cutting teeth are required for different thread sizes.

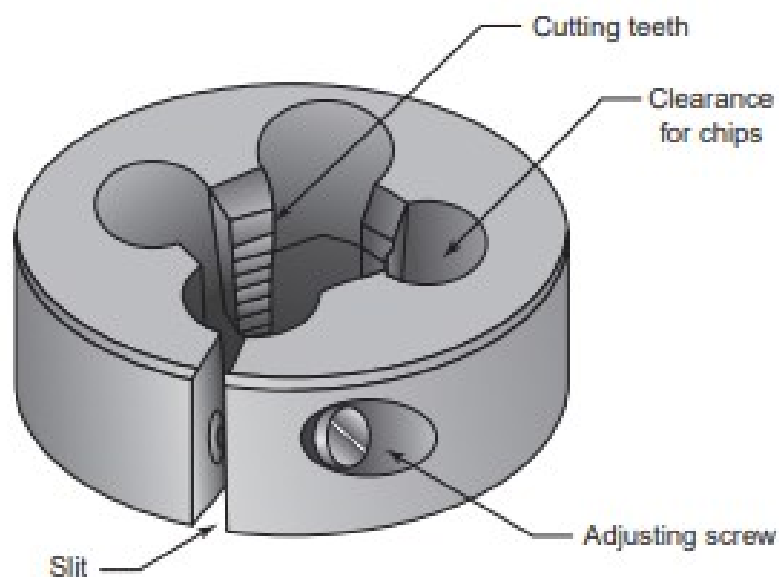

FIGURE 21.36: Threading die.

The term **thread chasing** is often applied to production operations that utilize self-opening dies. Two types of thread chasing equipment are available: (1) stationary self-opening dies, in which the workpiece rotates and the die does not, like a turning operation; and (2) revolving self-opening dies, in which the die rotates and the workpiece does not, like a drilling operation.

Two additional external threading operations should be mentioned: thread milling and thread grinding. **Thread milling** involves the use of a milling cutter to shape the threads of a screw. One possible setup is illustrated in Figure 21.37. In this operation a form-milling cutter, whose profile is that of the thread groove, is oriented at an angle equal to the helix angle of the thread and fed longitudinally as the workpiece is slowly rotated. In a variation of this operation, a multiple-form cutter is used, so that multiple screw threads can

be cut simultaneously to increase production rates. Possible reasons for preferring thread milling over thread chasing include (1) the size of the thread is too large to be readily cut with a die and (2) thread milling is generally noted to produce more accurate and smoother threads.

Thread grinding is similar to thread milling except the cutter is a grinding wheel with the shape of the thread groove, and the rotational speed of the grinding wheel is much greater than in milling. The process can be used to completely form the threads or to finish threads that have been formed by one of the previously discussed processes. Thread grinding is especially applicable for threads that have been hardened by heat treatment.

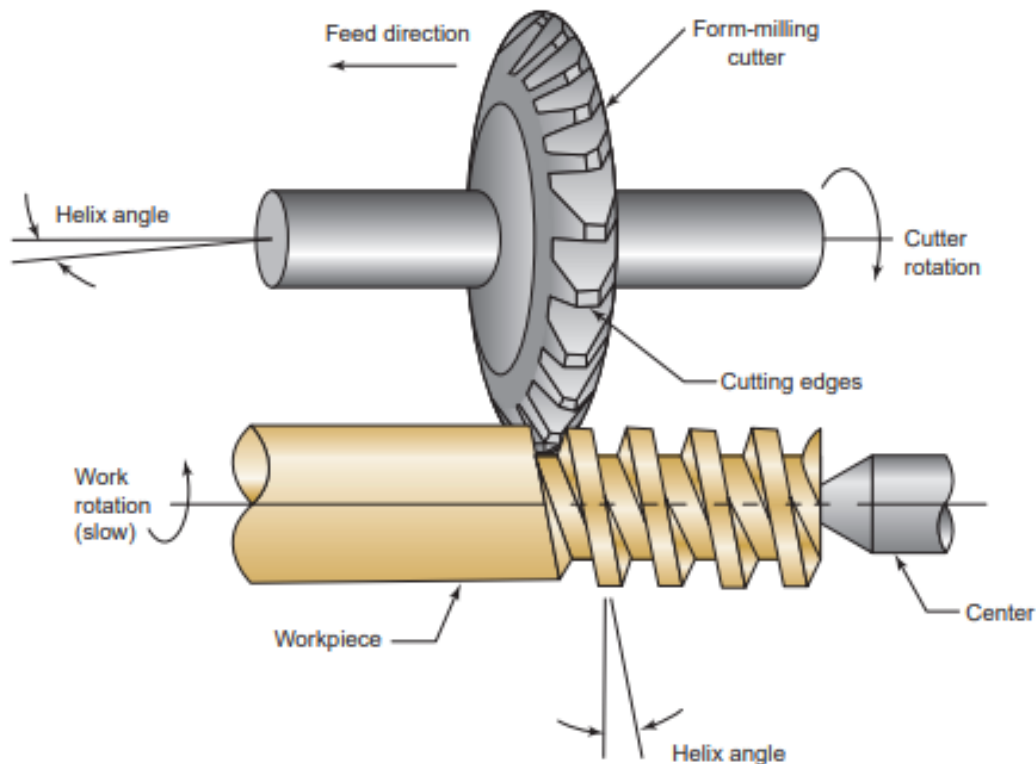

FIGURE 21.37: Thread milling using a form-milling cutter.

Internal Threads

The most common process for cutting internal threads is **tapping**, in which a cylindrical tool with cutting teeth arranged in a spiral whose pitch is equal to that of the screw threads, is simultaneously rotated and fed into a pre-existing hole. The operation is illustrated in Figure 21.14(b), and the cutting tool is called a **tap**. The end of the tool is slightly conical to facilitate entry into the hole. The initial hole size is approximately equal to the minor diameter of the screw thread. In the simplest version of the process, the tap is a solid piece and the tapping operation is performed on a drill press equipped with a tapping head, which allows penetration into the hole at a rate that corresponds to the screw pitch. At the end of the operation, the spindle rotation is reversed so the tap can be unscrewed from the hole.

In addition to solid taps, collapsible taps are available, just as self-opening dies are available for external threading. **Collapsible taps** have cutting teeth that automatically retract into the tool when the thread has been cut, allowing it to be quickly removed from the tapped hole without reversing spindle direction. Thus, shorter cycle times are possible.

Although production tapping can be accomplished on drill presses and other conventional machine tools (e.g., lathes, turret lathes), several types of specialized machines have been developed for higher production rates. Single-spindle tapping machines perform tapping one workpiece at a time, with manual or automatic loading and unloading of the starting blanks. Multiple-spindle tapping machines operate on multiple work parts simultaneously and provide for different hole sizes and screw pitches to be accomplished together. Finally, gang drills can be set up to perform drilling, reaming, and tapping in rapid sequence on the same part.

21.7.2 GEARS

Gears are machinery components used to transmit motion and power between rotating shafts. As illustrated in Figure 21.38, the transmission of rotational motion is achieved between meshing gears by teeth located around their

respective circumferences. The teeth have a special curved shape called an involute, which minimizes friction and wear between contacting teeth of meshing gears. Depending on the relative numbers of teeth of the two gears, the speed of rotation can be increased or decreased from one gear to the next, with a corresponding decrease or increase in torque. These speed effects are examined on numerical control positioning systems.

There are various gear types, the most basic and least complicated to produce is the **spur gear** represented in Figure 21.38. It has teeth that are parallel to the axis of the gear's rotation. A gear with teeth that form an angle relative to the axis of rotation is called a **helical gear**. The helical tooth design allows more than one tooth to be in contact for smoother operation. Spur and helical gears provide rotation between shafts whose axes are parallel. Other types, such as **bevel gears**, provide motion between shafts that are at an angle with each other, usually 90° . A **rack** is a straight gear (a gear of infinite radius), which allows rotational motion to be converted into linear motion (e.g., rack-and-pinion steering on automobiles). The variety of gear types is far too great for us to discuss them all, and the interested reader is referred to texts on machine design for coverage of gear design and mechanics. This section is concerned with the manufacture of gears.

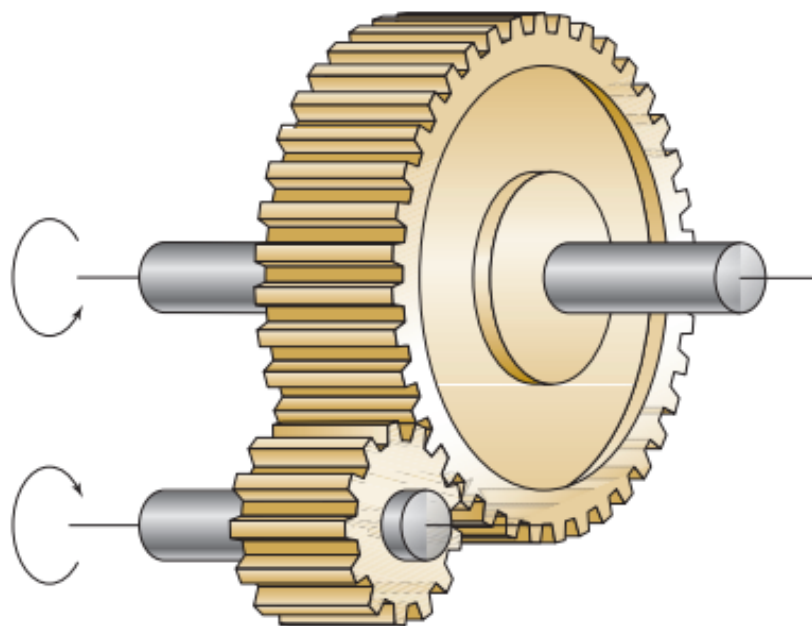

FIGURE 21.38: Two meshing spur gears.

Several of the shape processing operations discussed in previous chapters can be used to produce gears. These include investment casting, die casting, plastic injection molding, powder metallurgy, forging, and other bulk deformation operations (e.g., gear rolling,). The advantage of these operations over machining is material savings because no chips are produced. Sheet metal stamping operations are used to produce thin gears in watches and clocks. The gears produced by all of the preceding operations can often be used without further processing. In other cases, a basic shape processing operation such as casting or forging is used to produce a starting metal blank, and these parts are then machined to form the gear teeth. Finishing operations are often required to achieve the specified accuracies of the teeth dimensions.

The principal machining operations used to cut gear teeth are form milling, gear hobbing, gear shaping, and gear broaching. Form milling and gear broaching are considered to be forming operations in the sense of while gear hobbing and gear shaping are classified as generating operations. Finishing processes for gear teeth include gear shaving, gear grinding, and burnishing. Many of the processes used to make gears are also used to produce splines, sprockets, and other special machinery components.

Form Milling

In this process, illustrated in Figure 21.39, the teeth on a gear blank are machined individually by a form-milling cutter whose cutting edges have the shape of the spaces between the teeth on the gear. The machining operation is classified as forming because the shape of the cutter determines the geometry of the gear teeth. The disadvantage of form milling is that production rates are slow because each tooth space is created one at a time and the gear blank must be indexed between each pass to establish the correct size of the gear tooth, which also takes time. The advantage of form milling over gear hobbing (discussed next) is that the milling cutter is much less expensive. The slow production rates and relatively low cost tooling make form milling appropriate for low production quantities.

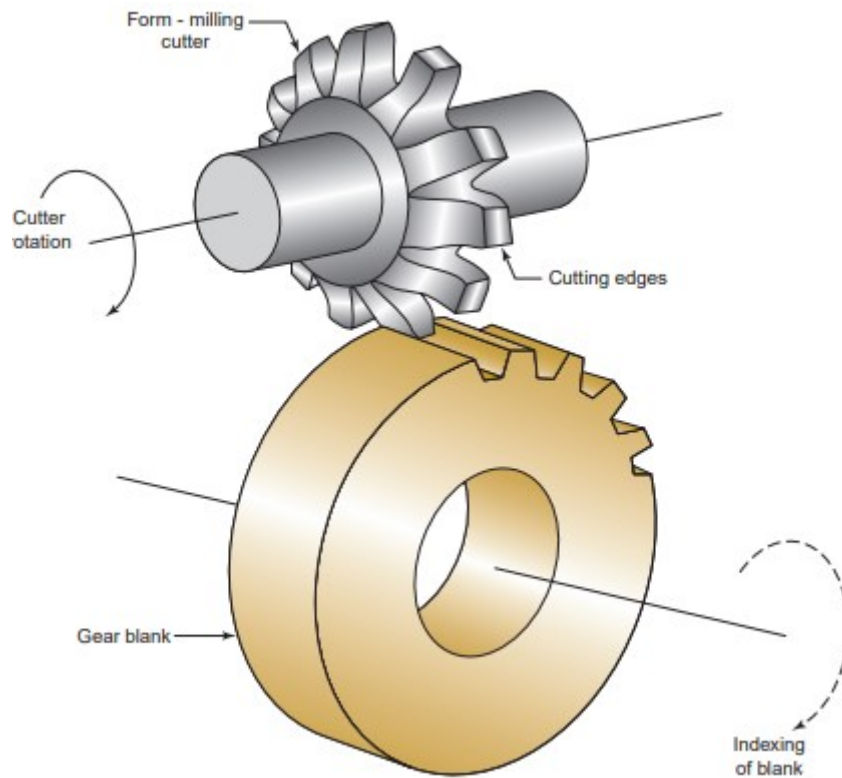

FIGURE 21.39: Form milling of gear teeth on a starting blank.

Gear Hobbing

Gear hobbing is also a milling operation, but the cutter, called a hob, is much more complex and therefore much more expensive than a form milling cutter. In addition, special milling machines (called ***hobbing machines***) are required to accomplish the relative speed and feed motions between the cutter and the gear blank. Gear hobbing is illustrated in Figure 21.40. As shown in the figure, the hob has a slight helix and its rotation must be coordinated with the much slower rotation of the gear blank in order for the hob's cutting teeth to mesh with the blank's teeth as they are being cut. This is accomplished for a spur gear by offsetting the axis of rotation of the hob by an amount equal to 90° less the helix angle relative to the axis of the gear blank. In addition to these rotary motions of the hob and the workpiece, a straight-line motion is also required to feed the hob relative to the gear blank throughout its thickness. Several teeth are cut simultaneously in hobbing, which allows for

higher production rates than form milling. Accordingly, it is a widely used gear making process for medium and high production quantities.

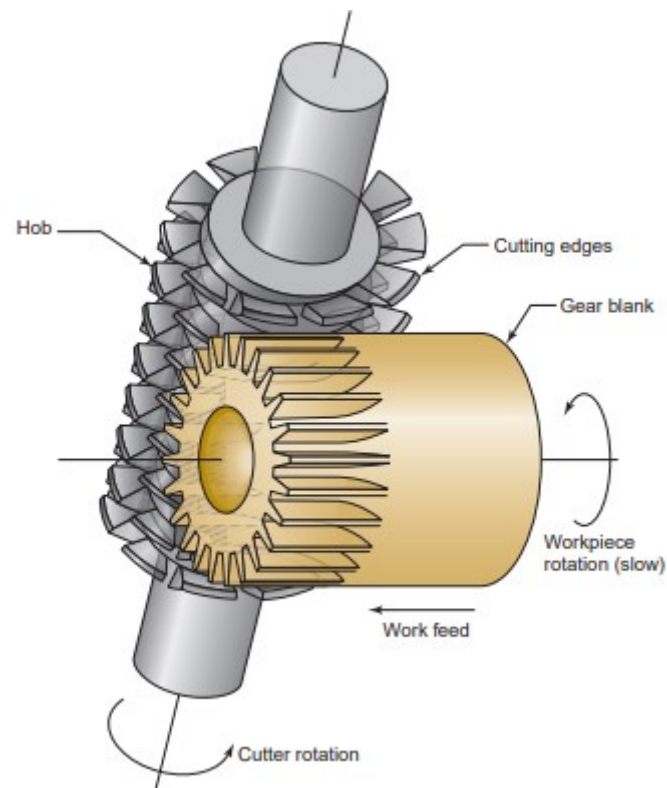

FIGURE 21.40: Gear hobbing.

Gear Shaping

In gear shaping, a reciprocating cutting tool motion is used rather than a rotational motion as in form milling and gear hobbing. Two quite different forms of shaping operation are used to produce gears. In the first type, a single-point tool takes multiple passes to gradually shape each tooth profile using computerized controls or a template. The gear blank is slowly rotated or indexed, with the same profile being imparted to each tooth. The procedure is slow and applied only in the fabrication of very large gears.

In the second type of gear shaping operation, the cutter has the general shape of a gear, with cutting teeth on one side. The axes of the cutter and the gear blank are parallel, as illustrated in Figure 21.41, and the action is similar to a pair of conjugate gears except that the reciprocation of the cutter is

gradually creating the form of the matching teeth in its mating component. At the beginning of the operation for a given gear blank, the cutter is fed into the blank after each stroke until the required depth has been reached. Then, after each successive pass of the tool, both the cutter and the blank are rotated a small amount (indexed) so as to maintain the same tooth spacing on each. Gear shaping by this second method is widely used in industry, and specialized machines (called **gear shapers**) are available to accomplish the process.

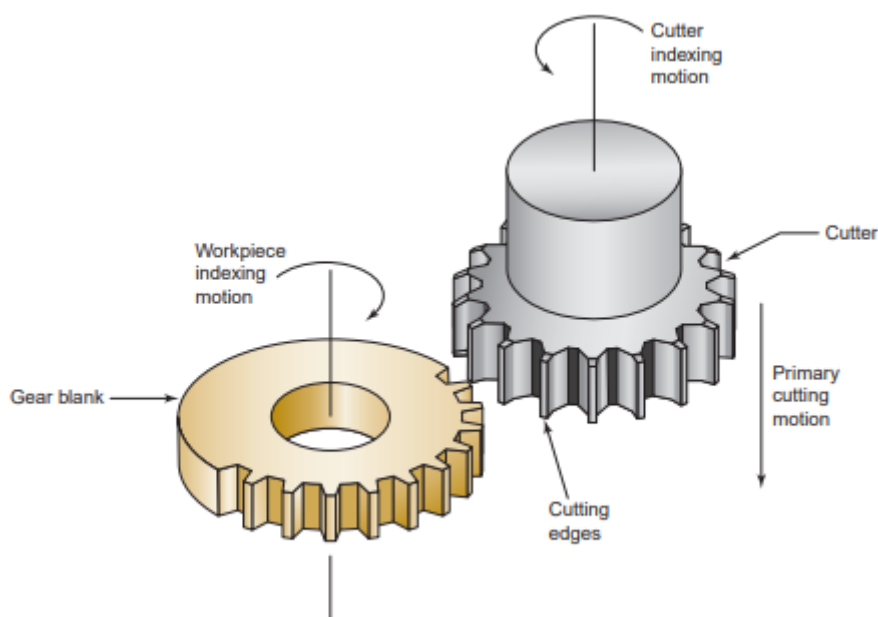

FIGURE 21.41: Gear shaping.

Gear Broaching

Broaching as a gear making process is noted for short production cycle times and high tooling cost. It is therefore economical only for high volumes. Good dimensional accuracy and fine surface finish are also features of gear broaching. The process can be applied for both external gears (the conventional gear) and internal gears (teeth on the inside of the gear). For making internal gears, the operation is similar to that shown in Figure 21.3(c), except the cross section of the tool consists of a series of gear-shaped cutting teeth of increasing size to form the gear teeth in successive steps as the broach is drawn through the work blank. To produce external gears, the broach is

tubular with inward-facing teeth. As mentioned, the cost of tooling in both cases is high due to the complex geometry.

Finishing Operations

Some metal gears can be used without heat treatment, while those used in more demanding applications are usually heat treated to harden the teeth for maximum wear resistance. Unfortunately, heat treatment often results in warpage of the workpiece, and the proper gear-tooth shape must be restored. Whether heat treated or not, some type of finishing operation is generally required to improve dimensional accuracy and surface finish of the gear after machining. Finishing processes applied to gears that have not been heat treated include shaving and burnishing. Finishing processes applied to hardened gears include grinding, lapping, and honing.

Gear shaving involves the use of a gear-shaped cutter that is meshed and rotated with the gear. Cutting action results from reciprocation of the cutter during rotation. Each tooth of the gear-shaped cutter has multiple cutting edges along its width, producing very small chips and removing very little metal from the surface of each gear tooth. Gear shaping is probably the most common industrial process for finishing gears. It is often applied to a gear prior to heat treatment, and then followed by grinding and/or lapping after heat treatment.

Gear burnishing is a plastic deformation process in which one or more hardened gear-shaped dies are rolled in contact with the gear, and pressure is applied by the dies to effect cold working of the gear teeth. Thus, the teeth are strengthened through strain hardening, and surface finish is improved.

Grinding, honing, and lapping are three finishing processes that can be used on hardened gears. **Gear grinding** can be based on either of two methods. The first is form grinding, in which the grinding wheel has the exact shape of the tooth spacing (similar to form milling), and a grinding pass or series of passes are made to finish form each tooth in the gear. The other method involves generating the tooth profile using a conventional straight-

sided grinding wheel. Both of these grinding methods are very time consuming and expensive.

Honing and lapping, respectively, are two finishing processes that can be adapted to gear finishing using very fine abrasives. The tools in both processes usually possess the geometry of a gear that meshes with the gear to be processed. Gear honing uses a tool that is made of either plastic impregnated with abrasives or steel coated with carbide. Gear lapping uses a cast iron tool (other metals are sometimes substituted), and the cutting action is accomplished by the lapping compound containing abrasives.

21.8 HIGH-SPEED MACHINING

One persistent trend throughout the history of metal machining has been the use of higher and higher cutting speeds. In recent years, there has been renewed interest in this area due to its potential for faster production rates, shorter lead times, reduced costs, and improved part quality. In its simplest definition, high-speed machining (HSM) means using cutting speeds that are significantly higher than those used in conventional machining operations. Some examples of cutting speed values for conventional and HSM are presented in Table 21.1, according to data compiled by Kennametal Inc.¹ Other definitions of HSM have been developed to deal with the wide variety of work materials and tool materials used in machining. One popular HSM definition is the DN ratio—the bearing bore diameter (mm) multiplied by the maximum spindle speed (rev/min). For high-speed machining, the typical DN ratio is between 500,000 and 1,000,000. This definition allows larger diameter bearings to fall within the HSM range, even though they operate at lower rotational speeds than smaller bearings. Typical HSM spindle velocities range between 8000 and 35,000 rpm, although some spindles today are designed to rotate at 100,000 rpm.

Another HSM definition is based on the ratio of horsepower to maximum spindle speed, or ***hp/rpm ratio***. Conventional machine tools usually have a higher hp/rpm ratio than machines equipped for high-speed machining. By this metric, the dividing line between conventional machining and HSM is around 0.005 hp/rpm. Thus, highspeed machining includes 50 hp spindles

capable of 10,000 rpm (0.005 hp/rpm) and 15 hp spindles that can rotate at 30,000 rpm (0.0005 hp/rpm).

Other definitions emphasize higher production rates and shorter lead times, rather than functions of spindle speed. In this case, important noncutting factors come into play, such as high rapid traverse speeds and quick automatic tool changes (“chip-to-chip” times of 7 s and less).

TABLE 21.1: COMPARISON OF CUTTING SPEEDS USED IN CONVENTIONAL VERSUS HIGH-SPEED MACHINING FOR SELECTED WORK MATERIALS								
SOLID TOOLS (END MILLS, DRILLS)					INDEXABLE TOOLS (FACE MILLS)			
WORK MATERIAL	CONVENTIONAL SPEED		HIGH CUTTING SPEED		CONVENTIONAL SPEED		HIGH CUTTING SPEED	
	m/min	ft/min	m/min	ft/min	m/min	ft/min	m/min	ft/min
Aluminum	300+	1000+	3000+	10,000+	600+	2000+	3600+	12,000+
Cast iron, soft	150	500	360	1200	360	1200	1200	400
Cast iron, ductile	105	350	250	800	250	800	900	3000
Steel, free machining	105	350	360	1200	360	1200	600	2000
Steel, alloy	75	250	250	800	210	700	360	1200
Titanium	40	125	60	200	45	150	90	300

NB: Solid tools are made of one solid piece, indexable tools use indexable inserts. Appropriate tool materials include cemented carbide and coated carbide of various grades for all materials, ceramics for all materials, polycrystalline diamond tools for aluminium, and cubic boron nitride for steels.

Requirements for high-speed machining include the following: (1) high-speed spindles using special bearings designed for high rpm operation; (2) high feed rate capability, typically around 50 m/min (2000 in/min); (3) CNC motion controls with “look ahead” features that allow the controller to see upcoming directional changes and to make adjustments to avoid undershooting or overshooting the desired tool path; (4) balanced cutting

tools, tool holders, and spindles to minimize vibration effects; (5) coolant delivery systems that provide pressures an order of magnitude greater than in conventional machining; and (6) chip control and removal systems to cope with the much larger metal removal rates in HSM. Also important are the cutting tool materials. As listed in Table 21.1, various tool materials are used for high-speed machining, and these materials are discussed in the following chapter.

Applications of HSM seem to divide into three categories. *One is in the aircraft industry, by companies such as Boeing, in which long airframe structural components are machined from large aluminum blocks.* Much metal removal is required, mostly by milling. The resulting pieces are characterized by thin walls and large surface-to-volume ratios, but they can be produced more quickly and are more reliable than assemblies involving multiple components and riveted joints. A second category involves the machining of aluminum by multiple operations to produce a variety of components for industries such as automotive, computer, and medical. Multiple cutting operations mean many tool changes as well as many accelerations and decelerations of the tooling. Thus, quick tool changes and tool path control are important in these applications. The third application category for HSM is in the die and mold industry, which fabricates complex geometries from hard materials. In this case, high-speed machining involves much metal removal to create the mold or die cavity and finishing operations to achieve fine surface finishes.

References

Ostwald, P. F., and J. Munoz. *Manufacturing Processes and Systems*, 9th ed. John Wiley & Sons, New York, 1997.

Trent, E. M., and Wright, P. K. *Metal Cutting*, 4th ed. Butterworth Heinemann, Boston, 2000.

Lindberg, R. A. *Processes and Materials of Manufacture*, 4th ed. Allyn and Bacon, Boston, 1990.

Kalpakjian, S., and Schmid S. R. Manufacturing Processes for Engineering Materials, 5th ed. Pearson Prentice Hall, Upper Saddle River, New Jersey, 2007.

REVIEW QUESTIONS

21.1 What are the differences between rotational parts and prismatic parts in machining?

21.2 Distinguish between generating and forming when machining work part geometries.

21.3 Give two examples of machining operations in which generating and forming are combined to create work part geometry.

21.4 Describe the turning process.

21.5 What is the difference between threading and tapping?

21.6 How does a boring operation differ from a turning operation?

21.7 What is meant by the designation 12 X 36 inch lathe?

21.8 Name the various ways in which a work part can be held in a lathe.

21.9 What is the difference between a live center and a dead center, when these terms are used in the context of workholding in a lathe?

21.10 How does a turret lathe differ from an engine lathe.

21.11 What is a blind hole?

21.12 What is the distinguishing feature of a radial drill press?

21.13 What is the difference between peripheral milling and face milling?

21.14 Describe profile milling.

21.15 What is pocket milling?

21.16 Describe the difference between up milling and down milling.

21.17 How does a universal milling machine differ from a conventional knee-and-column machine?

21.18 What is a machining center?

21.19 What is the difference between a machining center and a turning center?

21.20 What can a mill-turn center do that a conventional turning center cannot do?

21.21 How do shaping and planing differ?

21.22 What is the difference between internal broaching and external broaching?

21.23 Identify the three basic forms of sawing operation?

PROBLEMS

21.1 An engine lathe is used to turn a cylindrical work part 150 mm in diameter by 500 mm long. Cutting speed = 2.50 m/s, feed = 0.30 mm/rev, and depth of cut = 3.0 mm. Determine (a) cutting time and (b) metal removal rate.

21.2 In a production turning operation, the cylindrical workpiece is 375 mm long and 150 mm in diameter. Feed = 0.30 mm/rev, and depth of cut = 4.0 mm. What cutting speed must be used to achieve a machining time of 5.0 min?

21.4 A tapered surface is turned on an automatic lathe. The workpiece is 550 mm long with minimum and maximum diameters of 100 mm and 200 mm at opposite ends. Automatic controls on the lathe permit the surface speed to be maintained at a constant value of 200 m/min by adjusting the rotational speed as a function of workpiece diameter. Feed = 0.25 mm/rev, and depth of cut = 3.0 mm. The rough geometry of the piece has already been formed, and this operation will be the final cut. Determine (a) the time required to turn the taper and (b) the rotational speeds at the beginning and end of the cut (assume cutting starts at the smaller diameter).

21.10 A drilling operation is performed on a steel part using a 12.7-mm-diameter twist drill with point angle = 118° . The hole is a blind hole with a depth of 60 mm. Cutting speed = 15 m/min and feed = 0.20 mm/rev. Determine (a) cutting time of the operation and (b) metal removal rate after the drill bit reaches full diameter.

21.15 A face milling operation removes 6.0 mm from the top surface of a rectangular piece of aluminium that is 300 mm long by 90 mm wide by 75 mm thick. The cutter follows a path that is centered over the workpiece. It has four teeth and is 100 mm in diameter. Cutting speed = 2.0 m/s, and chip load = 0.27 mm/ tooth. Determine (a) machining time and (b) maximum metal removal rate during cutting.

21.23 A shaper is used to reduce the thickness of a 50-mm cast iron part to 45 mm. The top surface of the part is 550 mm long by 200 mm wide. Cutting speed = 0.125 m/sec, and feed = 0.50 mm/pass. The shaper ram is hydraulically driven and has a return stroke time that is 50% of the cutting stroke time. An extra 100 mm must be added before and after the part for acceleration and deceleration to take place. Assuming the ram moves parallel to the long dimension of the part, how long will it take to machine?